



**PROCUREMENT MANAGEMENT UNIT
ENVIRONMENTAL INVESTMENT FUND OF NAMIBIA**

**Request for Quotations of Goods for Works:
Water Treatment Project to improve local communities'
livelihoods in Namibia – (Kavango West & East Civil Works
Only for Mupini and Mupapama sites).
Procurement Reference No: W/RFQ/EIF-14/2023**

Issued on: 15 May 2023

Closing date & Time: 26 May 2023, 11H00AM

PARTICULARS OF BIDDER

Business Name :

Postal Address:

Telephone No:

Cell No.:

Contact Person:

E-Mail Address:

VAT Registration No:

Bid Amount: N\$

Procurement Management Unit

Environmental Investment Fund of Namibia, 8933 Heinitzburg Heights,
c/o Hienitzburg & Burg Streets,
Klein Windhoek
Windhoek, Namibia
Tel: +264 61 431 7700,

INFORMATION TO THE BIDDERS:

Bidders shall submit the Request for Quotations documents in a sealed envelope, duly marked with the Procurement Reference Number. W/RFQ/ EIF-14/2023. The inner and outer of the envelopes shall bear the Bidder's name and address, to be Hand delivered at the Environmental Investment Fund of Namibia: Friday, 26 May 2023 at 11H00AM.

Letter of Invitation

W/RFQ/ EIF-14/2023

15 May 2023

Dear Prospective Bidder,

Request for Quotations for Water Treatment Project to improve local communities' livelihoods in Namibia. (Kavango West & East- Civil Works for one site)

The Environmental Investment Fund of Namibia invites you to submit your quotation for the works described in detail hereunder.

Any resulting contract shall be subject to the terms and conditions referred to in the document.

Queries, if any, should be addressed to *Mr. David Hamukwaya* and emailed to: DHamukwaya@eif.org.na

Please prepare and submit your quotation in accordance with the instructions given or inform the undersigned if you will not be submitting a quotation.

There will be no compulsory site visit for this project, however, you are urged to make your own arrangements to visit the site to familiarize yourself with the conditions of the site.

Yours faithfully,

Mr. D.H. Hamukwaya

PROCUREMENT MANAGEMENT UNIT

Request for Quotations Document

Table of Contents

PART 1 – Bidding Procedures	1
Section I: Instructions to Bidders (ITB)	1.2
Section II: Bidding Forms	1.5
Section III: Evaluation Criteria	1.9
Part 2 – Employer’s Requirements	2
Section IV: Employer’s Requirements	2.2
Part 3 – Conditions of Contract and Contract Forms	3
Section V: General Conditions of Contract	3.2
Section VI: Special Conditions of Contract	3.27
Section VII: Contract Forms	3.32

Summary Description

This Standard Bidding Document for Procurement of Works is to be used when a prequalification process has not taken place before bidding and, therefore, post-qualification applies. A brief description of these documents is given below.

SBD for Procurement of Works

Summary

PART 1 – BIDDING PROCEDURES

Section I. Instructions to Bidders (ITB)

This Section provides relevant information to help Bidders prepare their bids. Information is also provided on the submission, opening, and evaluation of bids and on the award of Contracts.

Section II. Bidding Forms

This Section contains the forms which are to be completed by the Bidder and submitted as part of its Bid.

Section III. Evaluation Criteria

This section contains supplementary evaluation criteria which the Employer may choose to apply to the procurement under consideration.

PART 2 – EMPLOYER’S REQUIREMENTS

Section IV. Scope of Services and Performance Specifications Drawings

This Section contains the Specification and supplementary information that describe the works to be procured.

PART 3 – CONDITIONS OF CONTRACT AND CONTRACT FORMS

Section V. General Conditions of Contract

This Section contains the general clauses to be applied in all contracts. **The text of the clauses in this Section shall not be modified.**

Section VI. Special Conditions of Contract

The contents of this Section supplement the General Conditions of Contract and shall be prepared by the Employer.

Section VII. Contract Forms

This Section contains forms which, once completed, will form part of the Contract.

PART 1 – Bidding Procedures

SECTION I: INSTRUCTIONS TO BIDDERS

1. Rights of Public Entity

The Environmental Investment Fund of Namibia reserves the right:

- (a) to split the contract as per the lowest evaluated cost per lot; and
- (b) to accept or reject any quotation or to cancel the quotation process and reject all quotations at any time prior to contract award.

2. Preparation of Quotations

You are requested to quote for the works mentioned in Section II, by completing, signing, and returning:

- (a) the Quotation Letter in Section II with its annex and all other annexures (forms) where applicable;
- (b) the Priced Activity Schedule in Section II; and
- (c) the Specifications in Section IV; and
- (d) any other attachment as deemed appropriate

You are advised to carefully read the complete Request for Quotations document, including the Special Conditions of Contract in Section VI, before preparing your Quotation. The standard forms in this document may be retyped for completion but the Bidder is responsible for their accurate reproduction.

3. Validity of Quotations

The quotation validity period shall be 60 days from the date of bid submission deadline.

4. Eligibility Criteria

To be eligible to participate in this Quotation exercise, you should:

- (a) Have a valid certified copy of company Registration Certificate;
- (b) have an original valid good standing Tax Certificate;
- (c) have an original valid good Standing Social Security Certificate;
- (d) completed price schedule

5. Bid Security/Bid Securing Declaration

Bidders are required to submit subscribe to a Bid Securing Declaration for this procurement process.

6. Works Completion Period

The completion period for works shall be three (3) months after acceptance. Deviation in the completion period shall not be accepted.

7. Sealing and Marking of Quotations

Quotations should be sealed in a single envelope, clearly marked with the Procurement Reference Number, addressed to the Public Entity with the Bidder's name on the outer and inner side of the envelope.

8. Submission of Quotations

The closing date for the quotations is **Friday, 26 May 2023 at 11:00AM** (Namibian time) **late quotations will be rejected. Electronic submissions/quotations will not be accepted.**

Place of closing is:

The Quotation/Tender Box at
Environmental Investment Fund of Namibia
8933 Heinitzburg Heights
1st Floor, Reception
Windhoek
Namibia

9. Opening of Quotations

Quotations will be opened internally by the Public Entity immediately after the closing time. A record of the Quotation Opening stating the name of the bidders, the amount quoted, the presence or absence of a Bid Securing Declaration will be available to any bidder on request within three working days of the Opening.

10. Evaluation of Quotations

The Environmental Investment Fund of Namibia shall have the right to request for clarifications in writing during evaluation. Offers that are substantially responsive shall be compared on the basis of evaluated cost, subject to Margin of Preference where applicable, to determine the lowest evaluated quotation.

11. Technical Compliance

The specifications have to be met, but no credit will be given for exceeding the specifications.

12. Prices and Currency of Payment

Prices for the execution of works shall be fixed in Namibian Dollars as quoted. Quotations shall cover all costs of labour, materials, equipment, overheads, profits and all associated costs for performing the works, and shall include all duties. The whole cost of performing the works shall be included in the items stated, and the cost of any incidental works shall be deemed to be included in the prices quoted.

13. Margin of Preference

13.1. The applicable margins of preference and their application methodology are as follows:

N/A

13.2. Bidders applying for the Margin of Preference shall submit, upon request, evidence of:

N/A

14. Award of Contract

The Bidder having submitted the lowest evaluated responsive quotation and qualified to perform the works shall be selected for award of contract. Award of contract shall be by issue of a Purchase Order/Letter of Acceptance in accordance with terms and conditions contained in the Conditions of Contract.

15. Performance Security

The successful bidder shall upon acceptance of its offer submit a Performance Security as per the format contained in the Section VII for an amount of *10%* of the contract price.

16. Notification of Award and Debriefing

The Public Entity shall after awarding of contract promptly inform all unsuccessful bidders in writing of the name and address of the successful bidder and the contract amount within 7 days. Furthermore, the Public Entity shall attend to all requests for debriefing made in writing within 7 days of the unsuccessful bidders being informed of the award.

Data Form 1

SECTION II: BIDDING FORMS
QUOTATION LETTER
(to be completed by Bidders)

*[Complete this form with all the requested details and submit it as the first page of your quotation with the Priced Activity Schedule and documents requested. A signature and authorisation on this form will confirm that the terms and conditions of the RFQ prevail over any attachments. **If your quotation is not authorised, it will be rejected***

Quotation addressed to: [name of Public Entity]	
Procurement Reference Number:	
Subject matter of Procurement:	

We offer to execute the Works detailed in the Statement of Requirements, in accordance with the terms and conditions stated in your Request for Sealed Quotations referenced above.

We confirm that we are eligible to participate in this Quotation exercise and meet the eligibility criteria specified in Section 1: Instructions to Bidders

We undertake to abide by the Conduct of Bidders and Suppliers as provided under the Public Procurement Act during the procurement process and the execution of any resulting contract.

We have read and understood the content of the Bid Security/Bid Securing Declaration (BSD) attached hereto and subscribe fully to the terms and conditions contained therein. We further understand that this subscription could lead *[forfeiture of the security amount / disqualification on the grounds mentioned in the BDS]*

The validity period of our Quotation is _____ days *[insert number of days]* from the date of the bid submission deadline.

We confirm that the prices quoted in the Priced Activity Schedule are fixed and firm and will not be subject to revision or variation, if we are awarded the contract **prior to the expiry** date of the quotation validity.

Works will commence within _____ *[insert number]* days from date of issue of Purchase Order/ Letter of Acceptance.

Works will be completed within _____ *[insert number]* days from date of issue of Purchase Order/ Letter of acceptance.

Quotation Authorised by:

Name of Bidder		Company's Address and seal	
Contact Person			
Name of Person Authorising the Quotation:		Position:	Signature:
Date		Phone No./E-mail	

Data Form 2

BID SECURING DECLARATION
(Section 45 of Act)
(Regulation 37(1)(b) and 37(5))

Date:[Day/month/year].....

Procurement Ref No.:

To:[insert complete name of Public Entity and address].....

I/We* understand that in terms of section 45 of the Act a public entity must include in the bidding document the requirement for a declaration as an alternative form of bid security.

I/We* accept that under section 45 of the Act, I/we* may be suspended or disqualified in the event of

- (a) a modification or withdrawal of a bid after the deadline for submission of bids during the period of validity;**
- (b) refusal by a bidder to accept a correction of an error appearing on the face of a bid;**
- (c) failure to sign a procurement contract in accordance with the terms and conditions set forth in the bidding document, should I/We* be successful bidder; or**
- (d) failure to provide security for the performance of the procurement contract if required to do so by the bidding document.**

I/We* understand this bid securing declaration ceases to be valid if I am/We are* not the successful Bidder

Signed:
[insert signature of person whose name and capacity are shown]

Capacity of:
[indicate legal capacity of person(s) signing the Bid Securing Declaration]

Name:
[insert complete name of person signing the Bid Securing Declaration]

Duly authorized to sign the bid for and on behalf of: [insert complete name of Bidder]

Dated on _____ day of _____, _____
[insert date of signing]

Corporate Seal (where appropriate)

[Note*: In case of a joint venture, the bid securing declaration must be in the name of all partners to the joint venture that submits the bid.]

Data Form 3



Republic Of Namibia

Ministry of Labour, Industrial Relations and Employment Creation

Written undertaking in terms of section 138 of the Labour Act, 2015 and section 50(2)(D) of the Public Procurement Act, 2015

1. EMPLOYERS DETAILS

Company Trade Name:.....

Registration Number :.....

Vat Number:

Industry/Sector:

Place of Business:.....

Physical Address:.....

Tell No.:.....

Fax No.:.....

Email Address:.....

Postal Address:.....

Full name of Owner/Accounting Officer:.....

.....

Email Address:.....

2. PROCUREMENT DETAILS

Procurement Reference No.:.....

Procurement Description:

.....

.....

Anticipated Contract Duration:

Location where work will be done, good/services will be delivered:

.....

3. UNDERTAKING

I[insert full name], owner/representative

of[insert full name of company]

hereby undertake in writing that my company will at all relevant times comply fully with the relevant provisions of the Labour Act and the Terms and Conditions of Collective Agreements as applicable.

I am fully aware that failure to abide to such shall lead to the action as stipulated in section 138 of the labour Act, 2007, which include but not limited to the cancellation of the contract/licence/grant/permit or concession.

Signature:

Date:

Seal:.....

Data Form 4

Schedule of Contractor's Equipment Offered

The Bidder is to state below each item of major equipment which he guarantees to provide on the site within the time indicated hereunder. If such equipment is not owned by the Bidder, he shall attach a letter of intent from a reputable equipment (plant) hire firm that such equipment will be provided during the period of the Contract.

TYPE	REGISTRATION NUMBER	DESCRIPTION AND MAKE	YEAR OF MANUFACTURE	NUMBER OF HOURS SINCE NEW *	NAME OF OWNER **	WHERE EQUIPMENT CAN BE INSPECTED	DATE AVAILABLE

* In case of major overhauls, state the number of hours since last overhaul.

** When not owned by the Tenderer, also state whether the equipment will be held under a hire agreement or a hire-purchase agreement.

*** State the earliest date available on site or the number of days after award of contract.

The Contractor also undertakes to bring onto the site, without additional costs to the Employer, any additional construction equipment, which in the opinion of the Engineer is necessary for completing the contract within the tendered contract period.

Schedule of Contractor's Equipment Offered (Continued)

The Bidder is to state below each item of major equipment which he guarantees to provide on the site within the time indicated hereunder. If such equipment is not owned by the Bidder, he shall attach a letter of intent from a reputable equipment (plant) hire firm that such equipment will be provided during the period of the Contract.

TYPE	REGISTRATION NUMBER	DESCRIPTION AND MAKE	YEAR OF MANUFACTURE	NUMBER OF HOURS SINCE NEW *	NAME OF OWNER **	WHERE EQUIPMENT CAN BE INSPECTED	DATE AVAILABLE

* In case of major overhauls, state the number of hours since last overhaul.

** When not owned by the Tenderer, also state whether the equipment will be held under a hire agreement or a hire-purchase agreement.

*** State the earliest date available on site or the number of days after award of contract.

The Contractor also undertakes to bring onto the site, without additional costs to the Employer, any additional construction equipment, which in the opinion of the Engineer is necessary for completing the contract within the tendered contract period.

Data Form 5

Schedule of Personnel Offered

The Bidder is to state below the number of each category of personnel who he intends to provide on Site for the execution of the Works and in the case of professional and technical staff the number of years of appropriate experience after qualification. Such staff shall be named and guaranteed. Curriculum Vitae (CVs) must be attached.

PROFESSIONAL AND TECHNICAL	NATIONALITY		EXPERIENCE
	NAMIBIAN	NON-NAMIBIAN	
1. (a) Contractor's Site agent (Site Agent) Name: Qualifications:			
2. Welder and Concrete Foreman			
3. Earthworks and Pipe work Foreman			
4. Artisans			
5. Semi-skilled Labourers			
6. Other (specify):			
6. NON-TECHNICAL STAFF			NO OF
(a) Clerical Staff			
(d) Unskilled Labourers			

Data Form 6

Conventional Sub-Contractors

Schedule of Subcontractors

The bidder is to list below as defined in Sub-Clause 4.4 of the General Conditions of Contract, which he intends to employ to carry out parts of the work. The acceptance of this bid shall not be construed as being approval of any or all of the listed subcontractors. Should any or all of the subcontractors not be approved subsequent to the acceptance of the bid, it shall in no way invalidate the bid, and the tendered unit rates for the various items of work shall remain final and binding even in the event of a subcontractor not listed below being approved by the Employer. The work to be subcontracted shall be restricted to work of specialist nature, normally not carried out by a general contracting firm.

Sub-Contractors:

NAME AND ADDRESS OF SUBCONTRACTOR	SECTION OF WORKS AND ESTIMATED VALUE	NATURE OF WORK SUB-CONTRACTOR SPECIALIZES IN:

NB: Should the Bidder intend to make use of Sub-contractors; all contractual agreements shall comply with the requirements of the Contract and shall be submitted to the Engineer for approval.

Data Form 8

Signing Authority

In the cases where the Bidder is a Company, Corporation or Firm, the person whose signature appears below must be duly authorised to do so, whether by Articles of Association, Resolution, Power of Attorney or otherwise.

I/We, the undersigned am/are authorized to enter into the Contract on behalf of:

by virtue of _____

dated _____ a certified copy of which is attached to the Bid Document.

AS WITNESSES:

1. _____ **SIGNATURE OF BIDDER ***

2. _____ **DATE**

- **Signature to correspond with that on Bidding Form**

Data Form 9

Example: Letter of Intent from Financial Institution

Letter Head of Financial Institution

Date:

LETTER OF INTENT

This Serves to inform the Environmental Investment Fund of Namibia that the Financial Institution, herein represented by(the undersigned) in his/her capacity as, is willing to issue a Demand Guarantee to the value of N\$ in favour of the Environmental Investment Fund in the event that Bid #### be awarded to

The Demand Guarantee will be in the same wording and format as the one included in the Bid Dossier.

Signed:

Bill of Quantities

“The quantities appearing in the Schedule of Quantities are approximate only and are prepared for the comparison of tenders and award of contract. Payment will be made only for the quantities of work performed in accordance with the contract and it is understood that the scheduled quantities of work to be done and materials to be furnished may each be increased or decreased as herein provided”.

The prices and rates to be inserted in the Schedule of Quantities are to be the full inclusive prices to the Employer for the work described under the several items. Such prices shall cover all costs and expenses that may be required in and for the construction of the work described, and shall cover the cost of all general risks, liabilities, and obligations set forth or implied in the documents on which the Tender is based.

A price or rate is to be entered against each item in the Schedule of Quantities, whether the quantities are stated or not. An item against which no price is entered will be considered to be covered by the other prices or rates in the Schedule.

WATER TREATMENT PROJECT TO IMPROVE LOCAL COMMUNITIES' LIVELIHOODS IN NAMIBIA - CIVIL WORKS ONLY KAVANGO WEST



PRELIMINARY AND GENERAL

ITEM NO	PAYMENT	DESCRIPTION	UNIT	QTY	RATE	AMOUNT N\$
1	SANS 1200 AA	PRELIMINARY AND GENERAL				
		Fixed charges				
1.1	8.3.1	Contractual Requirements	Sum	1.00		
		Facilities required by Contractor				
1.2		Equipment	Sum	1.00		
1.3		Storage Shed	Sum	1.00		
		Time-related charges (for duration of contract, unless otherwise stated)				
1.4	8.4.1	Contractual requirements	Days	90.00		
1.5	8.4.2	Facilities for Contractor	Days	90.00		
1.6	8.4.3	General responsibilities and other time related obligations	Days	90.00		
1.7		Locating of Existing Services	Sum	1.00		

Total Carried Forward To Summary

WATER TREATMENT PROJECT TO IMPROVE LOCAL COMMUNITIES' LIVELIHOODS IN NAMIBIA - CIVIL WORKS ONLY KAVANGO WEST



PUMPHOUSE MATERIALS

ITEM NO	PAYMENT	DESCRIPTION	UNIT	QTY	RATE	AMOUNT N\$
3		PUMPHOUSE MATERIALS				
3.1		Pump House Materials				
3.1.1		Square Tubing 76.0 x 2mm	6m	16.00		
3.1.2		Expanded Steel Metal 25/50/4.5/3.0	SHT	16.00		
3.1.3		Lip Channel 75x50x20.2mm	6m	4.00		
3.1.4		Steel Sheet H/R 2540X1225X2.5mm	SHT	2.00		
3.1.5		Roof Sheeting IBR 0.3mm	3.6m	10.00		
3.1.6		Roof Screws +W S/Drilling 65mm	5kg	2.00		
3.1.7		Welding Electrode 2.5mm	5kg	2.00		
3.1.8		Cutting Disc 115x3x22.2mm	No.	2.00		
3.1.9		Cutting Disc 230x3x22.2mm	No.	2.00		
3.1.10		Grinding Disc 115x6mm	No.	2.00		
3.1.11		Grinding Disc 230x6mm	No.	2.00		
3.1.12		Padlock Mackie Iron 50mm B/P	No.	2.00		
3.1.13		Hinge Butterfly 60x70mm Weld on	No.	4.00		
3.1.14		Tubing Rectang 38x25x1.6mm	6m	4.00		
3.1.15		Mesh Welded 245/6.3mm	SHT	4.00		
3.1.15		Angles - 50x50x3 EA	6m	4.00		
3.1.16		Priming Paint-Zinc Chromate	/	10.00		
3.1.17		Base Plates - 4x150x3mm MS Plates	2.45m x	2.00		
3.1.18		Cast in Lugs - Y12 Rebar	13m	2.00		
3.1.19		Cement 42.5	50kg	40.00		
3.1.20		19mm Crush Stones	50kg	10.00		

Total Carried Forward

WATER TREATMENT PROJECT TO IMPROVE LOCAL COMMUNITIES' LIVELIHOODS IN NAMIBIA - CIVIL WORKS ONLY KAVANGO WEST



PUMPHOUSE MATERIALS

ITEM NO	PAYMENT	DESCRIPTION	UNIT	QTY	RATE	AMOUNT N\$
Brought Forward						-
		Sand	50kg	10.00		-
3.1.21		Bricks Standard 222x105x70 14mpa	No.	2,000.00		-
3.1.22		4mm 2 C + E Surfex white Roll	No.	40.00		-
3.1.23		Mes Single SSO + Euro 4x4 P4011	No.	6.00		-
3.1.24		20mm Pvc Conduit (4mtrs) SABS	No.	6.00		-
3.1.25		Extension Box Pvc 4x4 With KO	No.	6.00		-
3.1.26		20mm Pvc Coupling	No.	6.00		-
3.1.27		60 Watt Solar Light complete with back up battery	No.	2.00		-
						-
						-
						-
						-
						-
						-
						-
						-
						-
						-
						-
						-
						-
						-
						-
						-
						-
						-
						-
						-
						-
						-
						-
						-
						-
Total Carried Forward To Summary						-

WATER TREATMENT PROJECT TO IMPROVE LOCAL COMMUNITIES' LIVELIHOODS IN NAMIBIA - CIVIL WORKS ONLY KAVANGO WEST



SUMMARY OF SECTIONS						
SECTION	DESCRIPTION					AMOUNT N\$
1	PRELIMINARY AND GENERAL					-
2	SITE CLEARANCE					-
3	PUMPHOUSE MATERIALS					-
	SUBTOTAL					-
	ADD CONTINGENCIES (5%)					-
	SUBTOTAL					-
	Add 15% VAT					-
Total						-

Priced Activity Schedule

PRICED ACTIVITY SCHEDULE		
NOTE: - <div style="display: flex; justify-content: space-between; margin-top: 10px;"> VAT to be stated explicitly. VAT NUMBER..... </div>		
ITEM	DESCRIPTION	TOTAL COST (N\$)
	TOTAL SCHEDULE OF QUANTITIES	
	ADD 10% CONTIGENCY	
	SUB TOTAL	
	ADD 15% VAT	
TOTAL (VAT INCL.)		N\$

Section III - Evaluation Criteria

This section contains supplementary criteria that the Employer shall use to evaluate bids.

Evaluation Criteria

In addition to the eligibility criteria specified in Clause ITB4 of Section I 'Instruction to Bidders' (ITB) the following margin of preference and evaluation criteria shall apply:

1. Evaluation

In addition to the eligibility criteria listed in ITB 4 the following criteria shall apply:

a) Request for Quotation

This bid is in terms of the **National Bidding Procurement Act and in terms of Clause 32** is limited to the following:

1. Readily available commercial standard goods not specially manufactured to the particular specifications of the public entity;
2. Small services; or
3. Small works

If the estimated value of work does not exceed the prescribed threshold.

b) Range of Bid

Only bids that fall within a range of 10% below or 10% above the estimated construction cost, including provisional sums, contingencies, escalation and VAT, will be adjudicated.

c) Margin of Preference

Not Applicable

d) Evaluation Criteria

Quotations will be evaluated based on eligibility criteria and value for quote. The quote with the lowest value will be selected to execute the work.

e) Calculation of the Tender Index

The **Tender Index (It)** for each compliant Tender will be calculated **per each Contract Area** by weighted attributes using the formula below:

$$I_t = 0.3 \times P_s + 0.7 \times T_s$$

Section III- Evaluation Criteria

where:

Ps = the Price Score for the Tender under consideration, calculated **per each Contract Area**

Ts = the Technical Score for the Tender under consideration

The **Technical Score** will be calculated for each Tender in accordance with the following formula:

$$Ts = (T_F + T_X + T_C + T_M + T_N + T_D + T_P)$$

(f) Bank Rating

The Bidder shall submit a Bank rating from a commercial Bank operating in Namibia regarding the Bidder's ability to access credit facilities. The letter has to be dated not more than one month prior to the closing date of submission of bids and has to mention the name of the project and the amount (Namibian Dollars).

Kindly read below the definitions of the different bank rating codes:

A- Undoubted for Enquiry

B- Good for amount quoted

C- Good for amount quoted if strictly in way of business

D- Fair trade risk

E- Figures considered too high

F- Financial position unknown

G- Paper occasionally dishonoured

H- Paper frequently dishonoured.

Only bidders who score the minimum bank rating of C - will be considered for award

where the various elements of the equation are defined and derived as follows:

TYPICAL TECHNICAL SCORE TABLE

ITEM	NON-PRICE ATTRIBUTES TECHNICAL / CAPACITY/ PDN ATTRIBUTES	MAX. POINTS	CLAUSES IN SEC I: ITB
TF	Financial Resources (Data Form 2) Bid Declaration Form Bank Rating	2.5 2.5	ITB5
TX	Relevant Experience (Data Form 7) Comply with Experience Requirements Similar Projects completed in the past 3 years with References / Completion Certificates provided.	10 15	

Section III- Evaluation Criteria

TC	Relevant Competence: Staff Site agent Welder and Concrete Foreman Earthwork <ul style="list-style-type: none"> • As per Data Form 5 	20 10 10 10	
TM	Plant Capacity <ul style="list-style-type: none"> • As per Data Form 4 	10	
TL	Project Methodology <ul style="list-style-type: none"> • Bidder to give detailed methodology on how to execute the project. 	10	
TS	Technical Score	100	

Note: With reference to the Technical Score Table above, Bidders are required to fill in all the relevant Bidding Forms in Section II and to submit certified copies of supporting documentation that will enable the Evaluators to verify (and award points with regard to) the above-mentioned attributes. Bidders who achieve a Technical Score of less than 70 will be deemed to be non-compliant and will be disqualified from any further evaluation.

f) Targeted Procurement

Tenders will be evaluated according to pre-defined evaluation criteria in order to ensure that on the one hand, the work is carried out according to specification.

For the purpose of evaluation of tenders, the following definitions shall apply:

1. **“Small Medium Enterprise (SME)”** means a **“Namibian Supplier”** (as defined below) whose average actual annual turnover over the last three years, excluding Value Added Tax (VAT), did not exceed N\$2.5 Million per year.
2. **“Namibian Supplier”** means a **“Supplier”** (as defined below) who is 100% beneficially owned and controlled (directly or indirectly) by one or more Namibian citizens and whose management and daily business operations are under the control of and are performed by one or more of the Namibian citizens who effectively own and control it; it is furthermore a supplier who is registered with Namibian Inland Revenue for taxes and of whom the majority of business operations relating to the supply are located, and registered, if applicable, in Namibia and the majority of whose staff involved in these business operations is resident in Namibia.
3. **“Supplier”** is a generic reference to any supplier of works, services (including professional

Section III- Evaluation Criteria

services), or goods, being a business enterprise or legal entity, or joint venture that adheres to statutory labor practices and is an ongoing and independent enterprise for profit, providing a commercially useful function.

4. **“Previously Disadvantaged Namibian (PDN)”** means a Namibian citizen who belongs to a racial or ethnic group that formerly has been, or still is, directly or indirectly disadvantaged as a consequence of social, economic, or educational imbalances arising out of racially discriminating laws or practices before the independence of Namibia.

g) Adequacy of Technical Proposal

Evaluation of the Bidder's Technical Proposal will include an assessment of the Bidder's technical capacity to mobilize key equipment and personnel for the contract consistent with its proposal regarding work methods, scheduling, and material sourcing in sufficient detail and fully in accordance with the requirements stipulated in Section IV (Employer's Requirements).

PART 2 – Employer's Requirements

Section V – Employer’s Requirements**Specifications****CONTENTS**

<u>CLAUSE</u>	<u>DESCRIPTION</u>	<u>PAGE NO</u>
PORTION 1 : THE WORKS		
PS 1	GENERAL DESCRIPTION OF THE WORKS	2.3
PS 2	DESCRIPTION OF SITE AND ACCESS	2.4
PS 3	SITE CONDITIONS	2.4
PS 4	SOURCE OF MATERIALS FOR CONSTRUCTION PURPOSES	2.4
PS 5	DETAILS OF CONTRACT	2.5
PS 6	CONSTRUCTION PROGRAMME	2.5
PS 7	UPGRADING AND ULTERATIONS OF EXISTING SERVICES	2.5
PS 8	SITE FACILITIES AVAILABLE	2.6
PS 9	SITE FACILITIES REQUIRED	2.6
PS 10	FEATURES REQUIRING SPECIAL ATTENTION	2.7
PS 11	SUB-CONTRACTORS	2.8
PS 12	SURPLUS MATERIAL	2.8
PS 13	LABOUR REQUIREMENTS AND SAFTEY OF WORKMAN	2.8
PS 14	QUALITY CONTROL	2.9
PS 15	APPLICABLE STANDARDIZED AND PARTICULAR SPECIFICATIONS	2.11

SECTION 1 : PROJECT SPECIFICATIONS.

PS 1 GENERAL DESCRIPTION OF THE WORKS. SECTORS

PS1.1 Overview

A summary description of the envisaged scope is listed below. However, the **Environmental Investment Fund of Namibia** reserves the right to change the scope of the project considering the size, the requirements, and the changing conditions at different sites.

Overall objective.

The objective of the project is to promote water quality in order to improve the local communities’ livelihoods in Namibia.

Specific objectives

- (i) To improve ground and surface water quality in order to meet the Standards for drinking and agricultural activities.
- (ii) Increase the use of renewables and minimize greenhouse gas emissions by improving access to clean energy use as an enabler for climate resilient production.
- (iii) To provide local communities with alternative sustainable access to off-grid solar energy technologies such as water pumps and reverse osmosis units.

The scope of the project is as follows:

- (i) Construction of mini-Pump houses in order to house water treatment plants.

The Contract shall be executed briefly as follows:

- 1) Project planning and scoping.
- 2) Clearing and grubbing.
- 3) Construction of Water Treatment Plant Houses.
- 4) Testing, and commissioning following relevant SANS Specifications
- 5) Hand-over of the completed installation.
- 6) Removal of camp establishment, and trim and finish-off site.
- 7) The maintenance of the works and compliance with all other requirements of the Contractor’s defects liability.

PS 1.2 ENVIRONMENTAL REQUIREMENTS

PS 1.2.1 General

The Site of the Works is situated in an environment that is highly valued by the residents of the Kavango West community. A special duty of care is laid upon the Contractor to conduct all his operations in a manner specifically calculated to restrict his operations to the Construction Area and existing tracks, except where he must unavoidably move outside the area for the sole purpose of essential actions necessary, in the opinion of the Engineer, for the execution of the Work.

PS 2 DESCRIPTION OF THE SITE AND ACCESS

The Project is located in the Kavango West Region of Namibia.

Site Name	Latitude	Longitude
Mupini	17°51'47.97"S;	19°37'24.80"E
Mupupama	17°52'44.80"S;	20°15'16.80"E

PS 3 SITE CONDITIONS

The average annual rainfall for this area is approximately 570 mm per annum. No trial holes were dug to determine the nature and depth of the ground in the specific area for the project. However, it should be noted that the site condition indicates sandy soils that are collapsible during excavations

It remains the responsibility of the Bidder to satisfy himself as to the nature of the ground and subsoil in the areas of construction before submitting the relevant Tender rates. No claims arising thereof would be considered.

Adequate provision must be made for the protection of excavations against collapse and the ingress of ground and surface water, especially during the rainy season. All provisions for shoring and/or over-excavation of excavation activities, to ensure the safety of workers, will be taken to be included in the rate tendered for excavations, therefore over excavations shall not be paid for. The same applies to possible ground and surface water ingress.

PS 4 SOURCE OF MATERIALS FOR CONSTRUCTION PURPOSES

Depending on the properties of the material, the material for the layer works, selected bedding, and backfill might have to be obtained from different existing borrows pits. The contractor is to make his own investigations and arrangements with the owners of the borrow pits to obtain the specified material, and shall neatly finish off all borrow areas after use if required for the construction of the Works. Contractors are also advised to contact local geotechnical laboratories for assistance with finding suitable borrow pits.

PS 5 DETAILS OF CONTRACT

Special care must be taken not to damage or disturb any of the existing services such as existing water supply lines, telephone, and power lines. The location and protection of all services however remain the responsibility of the Contractor.

The Contractor will be responsible for ensuring that all his employees, and those of all Sub- Contractors, are fully conversant with all regulations laid down by the Local Authorities.

The Contractor will not be allowed unrestricted use of the site but must agree with the community forest and owner of the said property to the size and position of the areas required for the proper execution of the Works. All excess material excavated must be dumped and levelled in designated areas as approved by the community forest. The Contractor will be allowed areas for the storage of materials, erection of camp etc. and must limit himself to these areas, which are to be approved. Take note that very little accommodation is available in Kavango West, and the Contractor will have to make provision for such for him and his employees himself.

PS 6 CONSTRUCTION PROGRAMME

Within one week (seven days) of from the commencement date, the Contractor shall provide a detailed program, providing information on labor and plant resources and an estimated cash flow. The critical path shall be clearly defined and the program shall be drawn up in sufficient detail. The Contractor is allowed to plan and program the Works to suit himself but has to consider the request of the Employer as to which even are to be provided with services as a matter of priority. Where the services have been completed, shall be made available for use by the public as soon as possible. The Engineer will confirm the take-over of the completed services at the monthly site meetings. The contract is to be completed in 30 Calendar days, including Builders Holiday and special non-working days.

PS 7 UPGRADING AND ALTERATIONS OF EXISTING SERVICES

Alterations to existing services shall only be implemented as indicated by the Engineer / Project Manager. All excavations, lowering, relocating of existing services and reconstruction of manholes and catchpits shall be performed by the Contractor

PS 8 SITE FACILITIES AVAILABLE**PS 8.1 Water Supply**

The Contractor is to liaise with the community and owner of the said property to the

water take-off points. Arrangements for and payment of water used must be made with the Local Authorities and owner of the said property.

PS 8.2 Power Supply

The Contractor is advised to make his own arrangements.

PS 8.3 Camp Site and/or Base Camp

Areas which could be used for the possible establishment of the Contractor's camp will be pointed out to the Contractor. The Contractor shall make his own arrangement for the Contractor's Site Camp.

PS 9 SITE FACILITIES REQUIRED

PS 9.1 Laboratory Facilities

The Contractor's process control tests shall be carried out by an approved commercial laboratory. A laboratory on site is not a prerequisite.

PS 9.2 Facilities for Engineer / Project Manager

No Site facilities are to be provided for the Engineer / Project Manager. A site diary in A4-format shall be supplied and kept in the office of the Contractor. All major activities, events and achievements shall be recorded on a daily basis by the Contractor's Representative and co-signed by the Engineer / Project Manager's Representative or his delegate. A site instruction book shall also be kept in the office of the Contractor.

PS 9.3 Sanitary Facilities

The Contractor shall provide adequate toilet facilities for all personnel on Site.

PS 9.5 Rain Gauge

Rainfall during the construction period shall be measured on each site from a representative point. All equipment necessary is to be supplied, installed and maintained by the Contractor at his own expense and access to such point must be restricted. The Engineer must approve rainfall measurement and equipment.

PS 10 FEATURES REQUIRING SPECIAL ATTENTION

PS 10.1 Existing Services

Furthermore, no details regarding other possible existing services is available. The Contractor will be responsible to determine the position of all existing services with the

cooperation of staff. During site establishment and setting out, the position of existing lines shall be located prior to construction. Any damage to existing infrastructure shall be reported to the Engineer, and repaired at the Contractor’s cost.

PS 10.2 Care, Damage and Protection

When locating any services, the Contractor must take extreme care to avoid damage. The repair of all damaged existing services will be for the account of the Contractor.

PS 10.3 Requirements for Temporary Works

Any excavation or spoiled material (dumps) that may, in the opinion of the Engineer, be a danger to the public or its property must be barricaded in such a way that no accidents or damages will occur to either.

Two strategically placed warning lights must be placed at the barricaded site to warn the public during the night (if applicable).

The Contractor shall be responsible for his own access roads for construction and shall be expected to maintain these and make allowance for such under the Preliminary and General items.

PS 10.4 Safety requirements

The Contractor’s attention is drawn to the safety on the site. Although the construction area is remote and unoccupied, public does have access to the site and movement of people through the site might occur from time to time. The Contractor shall be responsible for the safety on the site at all times and he shall adhere to the laws and bylaws as well as the safety regulations. Works in progress shall be barricaded and warning signs erected as required by the law.

PS 10.5 Occupational Health and Safety Act

All Occupational Health and Safety Act regulations pertaining to the work being carried out must be adhered to. The Contractor’s employees and sub-contractor’s (including their employees) shall at all times be supervised by a competent supervisor appointed in writing in terms of Reg. 11.1 of the General Safety Regulations of the Occupational Health and Safety Act and made aware of his responsibilities.

PS 10.6 Extension of Time for Completion

Extension of time for completion shall be granted under the General Conditions of Contract for “Special Circumstances” arising from abnormal rainfall. Abnormal rainfall is defined as any rainfall in excess of 30% of the averages shown in the table below. The Contractor must, therefore, after a study of the rainfall pattern of the Kunene area of previous years, allowing for working time lost due to normal rainfall. No claim for

extension of time shall be considered where the working time was lost as the result of rain, which could normally have been expected to fall during a certain period of time.

PS 11 SUB-CONTRACTORS

PS 11.1 Sub-Contractors

If the Contractor intent to use a sub-contractor for certain activities of the works, he shall state in his Tender, which sub-contractor he intends to employ for any specific works. The Employer reserves the right, to accept or reject sub-contractor(s) if previous work was of an unsatisfactory standard.

PS 12 SURPLUS MATERIALS

PS 12.1 Surplus Materials

Due to the uncertain nature of certain aspects of the works at the tender stage, the Contractor shall make arrangements with his suppliers to return surplus material after completion of the contract. The Contractor is therefore required to store his material in such a manner that this will not be damaged whilst in storage. No payment will be made for material not used in the Works and that cannot be returned to the suppliers.

PS 13 LABOUR REQUIREMENTS AND SAFETY OF WORKMEN

The entire works shall be carried out in accordance with the requirements of all relevant Government Acts and Regulations. The Contractor shall not enter or work on, in or in close proximity of any existing structure, pump station, sump, manhole and such like without obtaining the prior permission of the Engineers.

The Contractor shall provide suitable and safe access in form of ladders, gangways, etc. to all parts of the works as may be required for construction purposes of for inspection by the Engineer.

The Contractor shall take precautions to ensure the safety of his employees and other persons on the site of the works.

All precautions shall be taken to protect workmen from falling material and other dangers whilst carrying out duties. Shafts and trenches shall in every way be kept safe for persons working therein.

Labor intensive construction methods should be used as far as possible and local laborers shall be employed. The Contractor shall abide by the relevant laws governing the employment and accommodation of labor. All arrangements affecting his labor force shall be the sole responsibility of the Contractor.

The Employer is also desirous of making a contribution towards equal opportunities for women, not only in respect of labor, but also throughout the human resource base of the Contract. No gender restrictions shall apply throughout the workforce. In respect of the latter and as far as is practicable, the Contractor is required to employ at least 30% of his unskilled labor force from the feminine gender which is to be done in consultation with the office of the Kunene community.

PS 14 QUALITY CONTROL

The Bidder shall take notice that his rates shall include all testing required in terms of Sub- Clause 7 of the Standardized Specifications of SABS 1200. The Contractor shall carry out all check and control tests as specified and the results shall be forwarded to the Engineer for evaluation. The Contractor will be solely responsible for the compliance of the works to the Specifications and to the satisfaction of the Engineer. To this end it will be the full responsibility of the Contractor to undertake appropriate quality control and quality assurance measures on site

The analysis of test results will not be done by statistical analysis. Individual tests shall pass the minimum specified requirements.

The test results of all testing carried out by or on behalf of the Contractor shall be submitted to the Engineer. In the event that the Contractor is not forthcoming with the test results the Engineer shall have the right to demand copies of the test results from the testing laboratory, irrespective whether the tests pass or fail the specified standards. Should the Contractor’s test results not be submitted within 3 days of the request, the Engineer shall have the right to withhold the certificate of payment until such time when he has received the requested test results.

The Engineer may order control tests at his discretion. If the tests ordered by the Engineer pass the specified requirement the Client shall reimburse the Contractor. If the tests fail, the Contractor shall pay for the tests and shall rectify the unsatisfactory work to specified standard. Only once the retesting ordered by the Engineer provides proof of workmanship of specified standard shall the Client reimburse the Contractor.

Should the Contractor fail to reimburse the commercial laboratory for the tests that have failed within the stipulated period of payment, the Engineer shall have the right to claim the monies due to the commercial laboratory with his professional fee account. On receipt of the monies the Engineer shall reimburse the commercial laboratory. The monies paid together with a 10% (ten percent) handling fee shall be deducted from the Contractor’s next progress claim.

PS 15 APPLICABLE STANDARDIZED AND PARTICULAR SPECIFICATIONS

For the purpose of this Contract the following standard specifications and particular specifications shall apply (NOT BOUND INTO THIS DOCUMENT):

SABS 1200 A: Civil Engineering Construction: Preliminary General

SABS 1200 C: Civil Engineering Construction: Site Clearance

SABS 1200 DB: Civil Engineering Construction: Earthworks
(Pipe trenches)

SABS 1200 GA: Civil Engineering Construction: Concrete
(Small works)

SABS 1200 L: Civil Engineering Construction: Pipeline

SABS 1200 LB: Civil Engineering Construction: Bedding

SABS 1200 LD: Civil Engineering Construction: Steel work

PART 3 – Conditions of Contract

Section V. General Conditions of Contract

Table of Clauses

A.	General.....	4
1.	Definitions.....	4
2.	Interpretation.....	6
3.	Language and Law	7
4.	Project Manager’s Decisions	7
5.	Delegation	7
6.	Communications	7
7.	Subcontracting	7
8.	Other Contractors.....	7
9.	Personnel and Equipment	7
10.	Employer’s and Contractor’s Risks	8
11.	Employer’s Risks	8
12.	Contractor’s Risks.....	8
13.	Insurance	8
14.	Site Data.....	9
15.	Contractor to Construct the Works	9
16.	The Works to Be Completed by the Intended Completion Date	9
17.	Approval by the Project Manager	9
18.	Safety	10
19.	Discoveries.....	10
20.	Possession of the Site.....	10
21.	Access to the Site	10
22.	Instructions.....	10
23.	Appointment of the Adjudicator	10
24.	Procedure for Disputes.....	11
B.	Time Control.....	11
25.	Program.....	11
26.	Extension of the Intended Completion Date	12
27.	Acceleration	12
28.	Delays Ordered by the Project Manager	12

29. Management Meetings.....	12
30. Early Warning.....	13
C. Quality Control.....	13
31. Identifying Defects.....	13
32. Tests	13
33. Correction of Defects.....	13
34. Uncorrected Defects.....	14
D. Cost Control.....	14
35. Contract Price.....	14
36. Changes in the Contract Price.....	14
37. Variations.....	14
38. Cash Flow Forecasts	15
39. Payment Certificates	15
40. Payments	16
41. Compensation Events.....	17
42. Tax	18
43. Currencies	18
44. Price Adjustment.....	18
45. Retention.....	19
46. Liquidated Damages	19
47. Bonus	20
48. Advance Payment	20
49. Securities.....	20
50. Dayworks	21
51. Cost of Repairs.....	22
52. Labour Clause	22
E. Finishing the Contract.....	23
53. Completion.....	23
54. Taking Over	23
55. Final Account.....	23
56. Operating and Maintenance Manuals	23
57. Termination.....	23
58. Fraud and Corruption.....	24
59. Payment upon Termination.....	25
60. Property.....	26
61. Release from Performance.....	26

General Conditions of Contract

A. General

1. Definitions

1.1 Boldface type is used to identify defined terms.

- (a) The Accepted Contract Amount means the amount accepted in the Notification of award for the execution and completion of the Works and the remedying of any defects.
- (b) The Activity Schedule is a schedule of the activities comprising the construction, installation, testing, and commissioning of the Works in a lump sum contract. It includes a lump sum price for each activity.
- (c) The Adjudicator is the person appointed jointly by the Employer and the Contractor to resolve disputes in the first instance, as provided for in GCC 23.
- (d) Bill of Quantities means the priced and completed Bill of Quantities forming part of the Bid.
- (e) Compensation Events are those defined in GCC Clause 41 hereunder.
- (f) The Completion Date is the date of completion of the Works as certified by the Project Manager, in accordance with GCC Sub-Clause 53.1.
- (g) The Contract is the Contract between the Employer and the Contractor to execute, complete, and maintain the Works. It consists of the documents listed in GCC Sub-Clause 2.3 below.
- (h) The Contractor is the party whose Bid to carry out the Works has been accepted by the Employer.
- (i) The Contractor's Bid is the completed bidding document submitted by the Contractor to the Employer.
- (j) The Contract Price is the Accepted Contract Amount stated in the Notification of award and thereafter as adjusted in accordance with the Contract.
- (k) Days are calendar days; months are calendar months unless otherwise stated.
- (l) Dayworks are varied work inputs subject to payment on a time basis for the Contractor's employees and Equipment, in addition to payments for associated Materials and Plant.
- (m) A Defect is any part of the Works not completed in accordance with the Contract.

- (n) The Defects Liability Certificate is the certificate issued by Project Manager upon correction of defects by the Contractor.
- (o) The Defects Liability Period is the period **named in the SCC** pursuant to Sub-Clause 33.1 and calculated from the Completion Date.
- (p) Adjudicator means the single person appointed under Clause 23.
- (q) Drawings means the drawings of the Works, as included in the Contract, and any additional and modified drawings issued by (or on behalf of) the Employer in accordance with the Contract, include calculations and other information provided or approved by the Project Manager for the execution of the Contract.
- (r) The Employer is the party who employs the Contractor to carry out the Works, **as specified in the SCC**.
- (s) Equipment is the Contractor’s machinery and vehicles brought temporarily to the Site to construct the Works.
- (t) “In writing” or “written” means hand-written, type-written, printed or electronically made, and resulting in a permanent record;
- (u) The Initial Contract Price is the Contract Price listed in the Employer’s Notification of award.
- (v) The Intended Completion Date is the date on which it is intended that the Contractor shall complete the Works. The Intended Completion Date is **specified in the SCC**. The Intended Completion Date may be revised only by the Project Manager by issuing an extension of time or an acceleration order.
- (w) Materials are all supplies, including consumables, used by the Contractor for incorporation in the Works.
- (x) Plant is any integral part of the Works that shall have a mechanical, electrical, chemical, or biological function.
- (y) The Project Manager is the person **named in the SCC** (or any other competent person appointed by the Employer and notified to the Contractor, to act in replacement of the Project Manager) who is responsible for supervising the execution of the Works and administering the Contract.
- (z) SCC means Special Conditions of Contract
- (aa) The Site is the area **defined as such in the SCC**.
- (bb) Site Investigation Reports are those that were included in

the bidding documents and are factual and interpretative reports about the surface and subsurface conditions at the Site.

- (cc) Specification means the Specification of the Works included in the Contract and any modification or addition made or approved by the Project Manager.
- (dd) The Start Date is **given in the SCC**. It is the latest date when the Contractor shall commence execution of the Works. It does not necessarily coincide with any of the Site Possession Dates.
- (ee) A Subcontractor is a person or corporate body who has a Contract with the Contractor to carry out a part of the work in the Contract, which includes work on the Site.
- (ff) Temporary Works are works designed, constructed, installed, and removed by the Contractor that are needed for construction or installation of the Works.
- (gg) A Variation is an instruction given by the Project Manager which varies the Works.
- (hh) The Works are what the Contract requires the Contractor to construct, install, and turn over to the Employer, **as defined in the SCC**.

2. Interpretation

2.1 In interpreting these GCC, words indicating one gender include all genders. Words indicating the singular also include the plural and words indicating the plural also include the singular. Headings have no significance. Words have their normal meaning under the language of the Contract unless specifically defined. The Project Manager shall provide instructions clarifying queries about these GCC.

2.2 If sectional completion is **specified in the SCC**, references in the GCC to the Works, the Completion Date, and the Intended Completion Date apply to any Section of the Works (other than references to the Completion Date and Intended Completion Date for the whole of the Works).

2.3 The documents forming the Contract shall be interpreted in the following order of priority:

- (a) Agreement,
- (b) Notification of award,
- (c) Contractor's Bid,
- (d) Special Conditions of Contract,
- (e) General Conditions of Contract,
- (f) Specifications,

- (g) Drawings,
 - (h) Bill of Quantities,¹ and
 - (i) any other document **listed in the SCC** as forming part of the Contract.
- 3. Language and Law** 3.1 The language of the Contract must be English and the law governing the Contract is the Law of Namibia.
- 4. Project Manager's Decisions** 4.1 Except where otherwise specifically stated, the Project Manager shall decide contractual matters between the Employer and the Contractor in the role representing the Employer.
- 5. Delegation** 5.1 Otherwise **specified in the SCC**, the Project Manager may delegate any of his duties and responsibilities to other people, except to the Adjudicator, after notifying the Contractor, and may revoke any delegation after notifying the Contractor.
- 6. Communications** 6.1 Communications between parties that are referred to in the Conditions shall be effective only when in writing to the addresses **specified in the SCC**. A notice shall be effective only when it is delivered.
- 7. Subcontracting** 7.1 The Contractor may subcontract with the approval of the Project Manager but may not assign the Contract without the approval of the Employer in writing. Subcontracting shall not alter the Contractor's obligations.
- 8. Other Contractors** 8.1 The Contractor shall cooperate and share the Site with other contractors, public authorities, utilities, and the Employer between the dates given in the Schedule of Other Contractors, as **referred to in the SCC**. The Contractor shall also provide facilities and services for them as described in the Schedule. The Employer may modify the Schedule of Other Contractors and shall notify the Contractor of any such modification.
- 9. Personnel and Equipment** 9.1 The Contractor shall employ the key personnel and use the equipment identified in its Bid, to carry out the Works or other personnel and equipment approved by the Project Manager. The Project Manager shall approve any proposed replacement of key personnel and equipment only if their relevant qualifications or characteristics are substantially equal to or better than those proposed in the Bid.
- 9.2 If the Project Manager asks the Contractor to remove a person who is a member of the Contractor's staff or work force, stating the reasons, the Contractor shall ensure that the person leaves the Site within seven days and has no further connection with the work in the Contract.
-

- 10. Employer's and Contractor's Risks**
- 10.1 The Employer carries the risks which this Contract states are Employer's risks, and the Contractor carries the risks which this Contract states are Contractor's risks.
- 11. Employer's Risks**
- 11.1 From the Start Date until the Defects Liability Certificate has been issued, the following are Employer's risks:
- (a) The risk of personal injury, death, or loss of or damage to property (excluding the Works, Plant, Materials, and Equipment), which are due to
 - (i) use or occupation of the Site by the Works or for the purpose of the Works, which is the unavoidable result of the Works or
 - (ii) negligence, breach of statutory duty, or interference with any legal right by the Employer or by any person employed by or contracted to him except the Contractor.
 - (b) The risk of damage to the Works, Plant, Materials, and Equipment to the extent that it is due to a fault of the Employer or in the Employer's design, or due to war or radioactive contamination directly affecting the country where the Works are to be executed.
- 11.2 From the Completion Date until the Defects Liability Certificate has been issued, the risk of loss of or damage to the Works, Plant, and Materials is an Employer's risk except loss or damage due to
- (a) a Defect which existed on the Completion Date,
 - (b) an event occurring before the Completion Date, which was not itself an Employer's risk, or
 - (c) the activities of the Contractor on the Site after the Completion Date.
- 12. Contractor's Risks**
- 12.1 From the Starting Date until the Defects Liability Certificate has been issued, the risks of personal injury, death, and loss of or damage to property (including, without limitation, the Works, Plant, Materials, and Equipment) which are not Employer's risks are Contractor's risks.
- 13. Insurance**
- 13.1 The Contractor shall provide, in the joint names of the Employer and the Contractor, insurance cover from the Start Date to the end of the Defects Liability Period, in the amounts and deductibles **stated in the SCC** for the following events which are due to the Contractor's risks:
- (a) loss of or damage to the Works, Plant, and Materials;

- (b) loss of or damage to Equipment;
 - (c) loss of or damage to property (except the Works, Plant, Materials, and Equipment) in connection with the Contract; and
 - (d) personal injury or death.
- 13.2 Policies and certificates for insurance shall be delivered by the Contractor to the Project Manager for the Project Manager's approval within 21 days after issue of notification of award. All such insurance shall provide for compensation to be payable in the types and proportions of currencies required to rectify the loss or damage incurred.
- 13.3 If the Contractor does not provide any of the policies and certificates required, the Employer may effect the insurance which the Contractor should have provided and recover the premiums the Employer has paid from payments otherwise due to the Contractor or, if no payment is due, the payment of the premiums shall be a debt due.
- 13.4 Alterations to the terms of insurance shall not be made without the approval of the Project Manager.
- 13.5 Both parties shall comply with any conditions of the insurance policies.
- 13.6 The policies which are in the joint names of the Contractor and the Employer shall contain a clause to include a waiver of subrogation of the Contractor's rights to the insurance carrier against the Employer.
- 14. Site Data** 14.1 The Contractor shall be deemed to have examined any Site Data **referred to in the SCC**, supplemented by any information available to the Contractor.
- 15. Contractor to Construct the Works** 15.1 The Contractor shall construct and install the Works in accordance with the Specifications and Drawings.
- 16. The Works to Be Completed by the Intended Completion Date** 16.1 The Contractor may commence execution of the Works on the Start Date and shall carry out the Works in accordance with the Program submitted by the Contractor, as updated with the approval of the Project Manager, and complete them by the Intended Completion Date.
- 17. Approval by the Project Manager** 17.1 The Contractor shall submit Specifications and Drawings showing the proposed Temporary Works to the Project Manager, for his approval.
- 17.2 The Contractor shall be responsible for design of Temporary

Works.

- 17.3 The Project Manager's approval shall not alter the Contractor's responsibility for design of the Temporary Works.
- 17.4 The Contractor shall obtain approval of third parties to the design of the Temporary Works, where required.
- 17.5 All Drawings prepared by the Contractor for the execution of the temporary or permanent Works, are subject to prior approval by the Project Manager before this use.
- 18. Safety** 18.1 The Contractor shall be responsible for the safety of all activities on the Site.
- 19. Discoveries** 19.1 Anything of historical or other interest or of significant value unexpectedly discovered on the Site shall be the property of the Employer. The Contractor shall notify the Project Manager of such discoveries and carry out the Project Manager's instructions for dealing with them.
- 20. Possession of the Site** 20.1 The Employer shall, after receiving the Performance security, the insurance covers and the Program for the Works all as per requirements, give possession of all parts of the Site to the Contractor within thirty days for execution of works in accordance to the Program for the Works. If possession of a part is not given by the date **stated in the SCC**, the Employer shall be deemed to have delayed the start of the relevant activities, and this shall be a Compensation Event.
- 21. Access to the Site** 21.1 The Contractor shall allow the Project Manager and any person authorized by the Project Manager access to the Site and to any place where work in connection with the Contract is being carried out or is intended to be carried out.
- 22. Instructions** 22.1 The Contractor shall carry out all instructions of the Project Manager which comply with the applicable laws where the Site is located.
- 22.2 The Contractor shall permit persons appointed by the Employer to inspect the Site and/or the accounts and records of the Contractor and its sub-contractors relating to the performance of the Contract, and to have such accounts and records audited by auditors appointed by the Employer if required by the Employer. The Contractor's attention is drawn to Sub-Clause 57.1 which provides, inter alia, that acts intended to materially impede the exercise of the inspection and audit rights provided for under Sub-Clause 22.2 constitute a prohibited practice subject to contract termination.
- 23. Appointment of the Adjudicator** 23.1 The Adjudicator shall be appointed jointly by the Employer and the Contractor, at the time of the Employer's issuance of the Notification of award. If, in the notification of award, the

Employer does not agree on the appointment of the Adjudicator, the Employer will request the Appointing Authority **designated in the SCC**, to appoint the Adjudicator within 15 days of receipt of such request.

23.2 Should the Adjudicator resign or die, or should the Employer and the Contractor agree that the Adjudicator is not functioning in accordance with the provisions of the Contract; a new Adjudicator shall be jointly appointed by the Employer and the Contractor. In case of disagreement between the Employer and the Contractor, within 30 days, the Adjudicator shall be designated by the Appointing Authority **designated in the SCC** at the request of either party, within 30 days of receipt of such request.

24. Procedure for Disputes

24.1 If the Contractor believes that a decision taken by the Project Manager was either outside the authority given to the Project Manager by the Contract or that the decision was wrongly taken, the decision shall be referred to the Adjudicator within 15 days of the notification of the Project Manager's decision.

24.2 The Adjudicator shall give a decision in writing within 30 days of receipt of a notification of a dispute.

24.3 The Adjudicator shall be paid by the hour at the **rate specified in the SCC**, together with reimbursable expenses of the types **specified in the SCC**, and the cost shall be divided equally between the Employer and the Contractor, whatever decision is reached by the Adjudicator. Either party may refer a decision of the Adjudicator to an Arbitrator within thirty (30) days of the Adjudicator's written decision. If neither party refers the dispute to arbitration within the above thirty (30) days, the Adjudicator's decision shall be final and binding.

24.4 The arbitration shall be conducted in accordance with the arbitration procedures published by the institution named and, in the place, specified **in the SCC**.

B. Time Control

25. Program

25.1 Within the time **stated in the SCC**, after the date of the Notification of award, the Contractor shall submit to the Project Manager for approval a Program showing the general methods, arrangements, order, and timing for all the activities in the Works. In the case of a lump sum contract, the activities in the Program shall be consistent with those in the Activity Schedule.

25.2 An update of the Program shall be a program showing the actual progress achieved on each activity and the effect of the progress achieved on the timing of the remaining work, including any changes to the sequence of the activities.

- 25.3 The Contractor shall submit to the Project Manager for approval an updated Program at intervals no longer than the period **stated in the SCC**. If the Contractor does not submit an updated Program within this period, the Project Manager may withhold the amount **stated in the SCC** from the next payment certificate and continue to withhold this amount until the next payment after the date on which the overdue Program has been submitted. In the case of a lump sum contract, the Contractor shall provide an updated Activity Schedule within 15 days of being instructed to by the Project Manager.
- 25.4 The Project Manager's approval of the Program shall not alter the Contractor's obligations. The Contractor may revise the Program and submit it to the Project Manager again at any time. A revised Program shall show the effect of Variations and Compensation Events.
- 26. Extension of the Intended Completion Date**
- 26.1 The Project Manager shall extend the Intended Completion Date if a Compensation Event(as defined in GCC 41) occurs or a Variation is issued which makes it impossible for Completion to be achieved by the Intended Completion Date without the Contractor taking steps to accelerate the remaining work, which would cause the Contractor to incur additional cost.
- 26.2 The Project Manager shall decide whether and by how much to extend the Intended Completion Date within 21 days of the Contractor asking the Project Manager for a decision upon the effect of a Compensation Event or Variation and submitting full supporting information. If the Contractor has failed to give early warning of a delay or has failed to cooperate in dealing with a delay, the delay by this failure shall not be considered in assessing the new Intended Completion Date.
- 27. Acceleration**
- 27.1 When the Employer wants the Contractor to finish before the Intended Completion Date, the Project Manager shall obtain priced proposals for achieving the necessary acceleration from the Contractor. If the Employer accepts these proposals, the Intended Completion Date shall be adjusted accordingly and confirmed by both the Employer and the Contractor.
- 27.2 If the Contractor's priced proposals for acceleration are accepted by the Employer, they are incorporated in the Contract Price and treated as a Variation.
- 28. Delays Ordered by the Project Manager**
- 28.1 The Project Manager may instruct the Contractor to delay the start or progress of any activity within the Works.
- 29. Management Meetings**
- 29.1 Either the Project Manager or the Contractor may require the other to attend a management meeting. The business of a

management meeting shall be to review the plans for remaining work and to deal with matters raised in accordance with the early warning procedure.

29.2 The Project Manager shall record the business of management meetings and provide copies of the record to those attending the meeting and to the Employer. The responsibility of the parties for actions to be taken shall be decided by the Project Manager either at the management meeting or after the management meeting and stated in writing to all who attended the meeting.

30. Early Warning 30.1 The Contractor shall warn the Project Manager at the earliest opportunity of specific likely future events or circumstances that may adversely affect the quality of the work, increase the Contract Price, or delay the execution of the Works. The Project Manager may require the Contractor to provide an estimate of the expected effect of the future event or circumstance on the Contract Price and Completion Date. The estimate shall be provided by the Contractor as soon as reasonably possible.

30.2 The Contractor shall cooperate with the Project Manager in making and considering proposals for how the effect of such an event or circumstance can be avoided or reduced by anyone involved in the work and in carrying out any resulting instruction of the Project Manager.

C. Quality Control

31. Identifying Defects 31.1 The Project Manager shall check the Contractor's work and notify the Contractor of any Defects that are found. Such checking shall not affect the Contractor's responsibilities. The Project Manager may instruct the Contractor to search for a Defect and to uncover and test any work that the Project Manager considers may have a Defect.

32. Tests 32.1 If the Project Manager instructs the Contractor to carry out a test not specified in the Specification to check whether any work has a Defect and the test shows that it does, the Contractor shall pay for the test and any samples. If there is no Defect, the test shall be a Compensation Event.

33. Correction of Defects 33.1 The Project Manager shall give notice to the Contractor of any Defects before the end of the Defects Liability Period, which begins at Completion, and is **defined in the SCC**. The Defects Liability Period shall be extended for as long as Defects remain to be corrected.

33.2 Every time notice of a Defect is given, the Contractor shall correct the notified Defect within the length of time specified by the Project Manager's notice.

- 34. Uncorrected Defects** 34.1 If the Contractor has not corrected a Defect within the time specified in the Project Manager’s notice, the Project Manager shall assess the cost of having the Defect corrected, and the Contractor shall pay this amount.

D. Cost Control

- 35. Contract Price** 35.1 In the case of an admeasurement contract, the Bill of Quantities shall contain priced items for the Works to be performed by the Contractor. The Bill of Quantities is used to calculate the Contract Price. The Contractor will be paid for the quantity of the work accomplished at the rate in the Bill of Quantities for each item.
- 35.2 In the case of a lump sum contract, the Activity Schedule shall contain the priced activities for the Works to be performed by the Contractor. The Activity Schedule is used to prepare interim valuations of works done.

Any errors or inconsistencies including front loading detected in the Activity Schedule at any time during the execution of the project shall be resolved as directed as by the Project Manager.

- 36. Changes in the Contract Price** 36.1 In the case of an admeasurement contract:
- (a) If the final quantity of the work done differs from the quantity in the Bill of Quantities for the particular item by more than 25 percent, provided the change exceeds 1 percent of the Initial Contract Price, the Project Manager shall adjust the rate to allow for the change.
 - (b) The Project Manager shall not adjust rates from changes in quantities if thereby the Initial Contract Price is exceeded by more than 15 percent, except with the prior approval of the Employer.
 - (c) If requested by the Project Manager, the Contractor shall provide the Project Manager with a detailed cost breakdown of any rate in the Bill of Quantities.
- 36.2 In the case of a lump sum contract, the Activity Schedule shall be amended by the Contractor to accommodate changes of Program or method of working made at the Contractor’s own discretion. Prices in the Activity Schedule shall not be altered when the Contractor makes such changes to the Activity Schedule.

- 37. Variations** 37.1 All Variations shall be included in updated Programs, and, in the case of a lump sum contract, also in the Activity Schedule, produced by the Contractor.
- 37.2 The Contractor shall provide the Project Manager with a quotation for carrying out the Variation when requested to do so by the Project Manager. The Project Manager shall assess the

quotation, which shall be given within seven (7) days of the request or within any longer period stated by the Project Manager and before the Variation is ordered.

37.3 If the Contractor's quotation is unreasonable, the Project Manager may order the Variation and make a change to the Contract Price, which shall be based on the Project Manager's own forecast of the effects of the Variation on the Contractor's costs.

37.4 If the Project Manager decides that the urgency of varying the work would prevent a quotation being given and considered without delaying the work, no quotation shall be given and the Variation shall be treated as a Compensation Event.

37.5 The Contractor shall not be entitled to additional payment for costs that could have been avoided by giving early warning.

37.6 In the case of an admeasurement contract, if the work in the Variation corresponds to an item description in the Bill of Quantities and if, in the opinion of the Project Manager, the quantity of work above the limit stated in Sub-Clause 38.1 or the timing of its execution do not cause the cost per unit of quantity to change, the rate in the Bill of Quantities shall be used to calculate the value of the Variation. If the cost per unit of quantity changes, or if the nature or timing of the work in the Variation does not correspond with items in the Bill of Quantities, the quotation by the Contractor shall be in the form of new rates for the relevant items of work.

38. Cash Flow Forecasts

38.1 When the Program, or, in the case of a lump sum contract, the Activity Schedule, is updated, the Contractor shall provide the Project Manager with an updated cash flow forecast.

39. Payment Certificates

39.1 The Contractor shall submit to the Project Manager monthly statements of the estimated value of the work executed less the cumulative amount certified previously.

39.2 The Project Manager shall check the Contractor's monthly statement and certify the amount to be paid to the Contractor.

39.3 The value of work executed shall be determined by the Project Manager.

39.4 The value of work executed shall comprise:

(a) In the case of an admeasurement contract, the value of the quantities of work in the Bill of Quantities that have been completed; or

(b) In the case of a lump sum contract, the value of work executed shall comprise the value of completed activities in

the Activity Schedule.

- 39.5 The value of work executed shall include the valuation of Variations and Compensation Events.
- 39.6 The Project Manager may exclude any item certified in a previous certificate or reduce the proportion of any item previously certified in any certificate in the light of later information.
- 39.7 Unless **otherwise specified in the SCC** Interim Payment may be made for Plant and Material delivered on site ready for incorporation within reasonable period of time in the permanent works, subject to the Contractor transferring ownership to the Employer and providing, where applicable, the right of the transfer of ownership vested upon the Contractor by its supplier.

Notwithstanding the transfer of ownership, the responsibility for care and custody thereof together with the risk of loss or damage thereto shall remain with the Contractor until taking over of the works or part thereof in which such Plant and Materials are incorporated and shall make good at its own cost any loss or damage that may occur to the works or part thereof from any cause whatsoever during such period prior to the taking over.

40. Payments

- 40.1 Payments shall be adjusted for deductions for advance payments and retention. The Employer shall pay the Contractor the amounts certified by the Project Manager within 30 days of the date of each certificate. If the Employer makes a late payment, the Contractor shall be paid interest on the late payment in the next payment. Interest shall be calculated from the date by which the payment should have been made up to the date when the late payment is made at the prevailing rate of interest at the legal rate.
- 40.2 If an amount certified is increased in a later certificate or as a result of an award by the Adjudicator or an Arbitrator, the Contractor shall be paid interest upon the delayed payment as set out in this clause. Interest shall be calculated from the date upon which the increased amount would have been certified in the absence of dispute.
- 40.3 Unless otherwise stated, all payments and deductions shall be paid or charged in the proportions to the Contract Price.
- 40.4 Items of the Works for which no rate or price has been entered in shall not be paid for by the Employer and shall be deemed covered by other rates and prices in the Contract.

41. Compensation Events

41.1 The following shall be Compensation Events:

- (a) The Employer does not give access to a part of the Site by the Site Possession Date pursuant to GCC Sub-Clause 20.1.
- (b) The Employer modifies the Schedule of Other Contractors in a way that affects the work of the Contractor under the Contract.
- (c) The Project Manager orders a delay or does not issue Drawings, Specifications, or instructions required for execution of the Works on time.
- (d) The Project Manager instructs the Contractor to uncover or to carry out additional tests upon work, which is then found to have no Defects.
- (e) The Project Manager unreasonably does not approve a subcontract to be let.
- (f) Ground conditions are substantially more adverse than could reasonably have been assumed before issuance of the Notification of award from the information issued to bidders (including the Site Investigation Reports), from information available publicly and from a visual inspection of the Site.
- (g) The Project Manager gives an instruction for dealing with an unforeseen condition, caused by the Employer, or additional work required for safety or other reasons.
- (h) Other contractors, public authorities, utilities, or the Employer does not work within the dates and other constraints stated in the Contract, and they cause delay or extra cost to the Contractor.
- (i) The advance payment is delayed.
- (j) The effects on the Contractor of any of the Employer's Risks.
- (k) The Project Manager unreasonably delays issuing a Certificate of Completion.
- (l) In situations of Force Majeure which makes the contractor's performance of its obligations under the Contract impossible or so impractical as to be considered impossible under the circumstances. Such events shall be limited to:
 - (a) reason of any exceptionally adverse weather conditions (as specified in the BDS) and

- (b) reason of civil commotion, strike or lockout affecting any of the trades employed upon the Works or any of the trades engaged in the preparation, manufacture or transportation of any of the goods or materials required for the Works.

41.2 If a Compensation Event would cause additional cost or would prevent the work being completed before the Intended Completion Date, the Contract Price shall be increased and/or the Intended Completion Date shall be extended. The Project Manager shall decide whether and by how much the Contract Price shall be increased and whether and by how much the Intended Completion Date shall be extended.

41.3 As soon as information demonstrating the effect of each Compensation Event upon the Contractor's forecast cost has been provided by the Contractor, it shall be assessed by the Project Manager, and the Contract Price shall be adjusted accordingly. If the Contractor's forecast is deemed unreasonable, the Project Manager shall adjust the Contract Price based on the Project Manager's own forecast. The Project Manager shall assume that the Contractor shall react competently and promptly to the event.

41.4 The Contractor shall not be entitled to compensation to the extent that the Employer's interests are adversely affected by the Contractor's not having given early warning or not having cooperated with the Project Manager.

42. Tax

42.1 The Project Manager shall adjust the Contract Price if taxes, duties, and other levies are changed between the date 30 days before the submission of bids for the Contract and the date of the last Completion certificate. The adjustment shall be the change in the amount of tax payable by the Contractor, provided such changes are not already reflected in the Contract Price or are a result of GCC Clause 44.

43. Currencies

43.1 Where payments are made in currencies other than the currency of the Employer's country **specified in the SCC**, the exchange rates used for calculating the amounts to be paid shall be the exchange rates stated in the Contractor's Bid.

44. Price Adjustment

44.1 Prices shall be adjusted for fluctuations in the cost of inputs only if **provided for in the SCC**. If so provided, the amounts certified in each payment certificate, before deducting for Advance Payment, shall be adjusted by applying the respective price adjustment factor to the payment amounts due in each currency. A separate formula of the type indicated below applies to each Contract currency:

$$P_c = A_c + B_c \text{ Imc/Ioc}$$

where:

P_c is the adjustment factor for the portion of the Contract Price payable in a specific currency “c.”

A_c and B_c are coefficients² **specified in the SCC**, representing the nonadjustable and adjustable portions, respectively, of the Contract Price payable in that specific currency “c;” and

Imc is the index prevailing at the end of the month being invoiced and Ioc is the index prevailing 28 days before Bid opening for inputs payable; both in the specific currency “c.”

- 44.2 If the value of the index is changed after it has been used in a calculation, the calculation shall be corrected, and an adjustment made in the next payment certificate. The index value shall be deemed to take account of all changes in cost due to fluctuations in costs.

45. Retention

- 45.1 The Employer shall retain from each payment due to the Contractor the proportion **stated in the SCC** until Completion of the whole of the Works.
- 45.2 Upon the issue of a Certificate of Completion of the Works by the Project Manager, in accordance with GCC 53.1, half the total amount retained shall be repaid to the Contractor and half when the Defects Liability Period has passed and the Project Manager has certified that all Defects notified by the Project Manager to the Contractor before the end of this period have been corrected. The Contractor may substitute retention money with an “on demand” Bank guarantee.

46. Liquidated Damages

- 46.1 The Contractor shall pay liquidated damages to the Employer at the rate per day **stated in the SCC** for each day that the Completion Date is later than the Intended Completion Date. The total amount of liquidated damages shall not exceed the amount **defined in the SCC**. The Employer may deduct liquidated damages from payments due to the Contractor. Payment of liquidated damages shall not affect the Contractor’s liabilities.
- 46.2 If the Intended Completion Date is extended after liquidated damages have been paid, the Project Manager shall correct any overpayment of liquidated damages by the Contractor by adjusting the next payment certificate. The Contractor shall be paid interest on the overpayment, calculated from the date of payment to the date of repayment, at the rates specified in GCC

Sub-Clause 40.1.

47. Bonus

47.1 The Contractor shall be paid a Bonus calculated at the rate per calendar day **stated in the SCC** for each day (less any days for which the Contractor is paid for acceleration) that the Completion is earlier than the Intended Completion Date. The Project Manager shall certify that the Works are complete, although they may not be due to be complete.

48. Advance Payment

48.1 The Employer shall make advance payment to the Contractor of the amounts **stated in the SCC** by the date **stated in the SCC**, against provision by the Contractor of an Unconditional Bank Guarantee in a form and by a bank acceptable to the Employer in amounts equal to the advance payment. The Guarantee shall remain effective until the advance payment has been repaid, but the amount of the Guarantee shall be progressively reduced by the amounts repaid by the Contractor. Interest shall not be charged on the advance payment.

48.2 The Contractor is to use the advance payment only to pay for Equipment, Plant, Materials, and mobilization expenses required specifically for execution of the Contract. The Contractor shall demonstrate that advance payment has been used in this way by supplying copies of invoices or other documents to the Project Manager.

48.3 The advance payment shall be repaid by deducting proportionate amounts from payments otherwise due to the Contractor, following the schedule of completed percentages of the Works on a payment basis. No account shall be taken of the advance payment or its repayment in assessing valuations of work done, Variations, price adjustments, Compensation Events, Bonuses, or Liquidated Damages.

49. Securities

49.1 The Performance Security shall be provided to the Employer no later than the date specified in the Notification of award and shall be issued in an amount **specified in the SCC**, by a bank and denominated in the Namibian Dollars. The Performance Security shall be valid until a date 30 days from the date of issue of the Certificate of Completion in the case of a Bank Guarantee.

49.2 (a) Where the contractor has benefitted from the application of the Margin of Preference for employment of local manpower, it shall:

(i) in the execution of the contract, fulfill its obligation of maintaining local manpower force for 80 % or more of the man-days deployed in the execution of the Works with which it satisfied the criteria of eligibility for being awarded the contract in application of the Margin of Preference; and

- (ii) concurrently with the above performance security, provide a preference security to guarantee it will fulfill its obligation in that respect.
- (b) For contracts above N\$ 5 M, the preference security shall be in the form of an “on demand” bank guarantee for an amount in a convertible currency equivalent to the difference between its bid price and the bid price of the lowest bid if the Margin of Preference was not applicable. It shall be issued by a commercial bank located in the Republic of [Insert name of country].
- (c) For contracts up to N\$ 5 M, an amount equal to the value of the preference security shall be retained from progressive payments to the contractor, to constitute the guarantee for the preference security.
- (d) The preference security shall be valid until the Contractor has completed the Works and a Completion Certificate has been issued by the Employer’s Representative as per GCC 53.
- (e) The cost of providing the security shall be borne by the Contractor.

49.3 Where a Preference Security is applicable:

- (i) the Employer’s Representative shall monitor the employment of local manpower throughout the execution of the contract and shall from time to time request a report from the contractor on the percentage of total men-days deployed using local manpower.
- (ii) the Contractor shall submit the local manpower employment reports as often as it is reasonably requested by the Employer’s Representative.
- (iii) the Employer’s and Contractor’s representatives shall consult each other to ensure that the Contractor’s obligation towards local manpower employment is met during the Works execution.
- (iv) At the time of works completion, the Contractor shall submit a certified audited report to the Employer to substantiate the actual percentage of local manpower employed throughout the execution of the works.
- (v) The preference security shall be forfeited by the employer in case of failure on the part of the contractor to employ at least 80% of the local manpower in the execution of the Works.

50. Dayworks

50.1 If applicable, the Dayworks rates in the Contractor’s Bid shall be used only when the Project Manager has given written instructions in advance for additional work to be paid for in that way.

- 50.2 All work to be paid for as Dayworks shall be recorded by the Contractor on forms approved by the Project Manager. Each completed form shall be verified and signed by the Project Manager within two days of the work being done.
- 50.3 The Contractor shall be paid for Dayworks subject to obtaining signed Dayworks forms.
- 51. Cost of Repairs**
- 51.1 Loss or damage to the Works or Materials to be incorporated in the Works between the Start Date and the end of the Defects Correction periods shall be remedied by the Contractor at the Contractor's cost if the loss or damage arises from the Contractor's acts or omissions.
- 52. Labour Clause**
- 52.1 (a) The rates of remuneration and other conditions of work of the employees of the Contractor shall not be less favorable than those established for work of the same character in the trade concerned-
- (i) by collective agreement applying to a substantial proportion of the workers and employers in the trade concerned;
 - (ii) by arbitration awards; or
 - (iii) by Remuneration Regulations made under the Labour Act, 2007.
- (b) Where remuneration and conditions of work are not regulated in a manner referred to at (a) above, the rates of the remuneration and other conditions of work shall be not less favourable than the general level observed in the trade in which the contractor is engaged by employers whose general circumstances are similar.
- 52.2 No Contractor shall be entitled to any payment in respect of work performed in the execution of the contract unless he has, together with his claim for payment, filed a certificate:
- (a) stating the rates of remuneration and hours of work of the various categories of employees employed in the execution of the contracts;
 - (b) stating whether any remuneration payable in respect of work done is due;
 - (c) containing such other information as the Chief Executive Officer of the Public Body administering the contract may require to satisfy himself that the provisions under this clause have been complied with.
- 52.3 Where the Chief Executive Officer of the Public Entity administering the contract is satisfied that remuneration is still

due to an employee employed under this contract at the time the claim for payment is filed under subsection *[Insert number]*, he may, unless the remuneration is sooner paid by the Contractor, arrange for the payment of the remuneration out of the money payable under this contract.

52.4 Every Contractor shall display a copy of this clause of the contract at the place at which the work required by the contract is performed.

E. Finishing the Contract

- 53. Completion** 53.1 The Contractor shall request the Project Manager to issue a Certificate of Completion of the Works, and the Project Manager shall do so upon deciding that the whole of the Works is completed.
- 54. Taking Over** 54.1 The Employer shall take over the Site and the Works within seven days of the Project Manager's issuing a certificate of Completion.
- 55. Final Account** 55.1 The Contractor shall supply the Project Manager with a detailed account of the total amount that the Contractor considers payable under the Contract before the end of the Defects Liability Period. The Project Manager shall issue a Defects Liability Certificate and certify any final payment that is due to the Contractor within 60 days of receiving the Contractor's account if it is correct and complete. If it is not, the Project Manager shall issue within 60 days a schedule that states the scope of the corrections or additions that are necessary. If the Final Account is still unsatisfactory after it has been resubmitted, the Project Manager shall decide on the amount payable to the Contractor and issue a payment certificate.
- 56. Operating and Maintenance Manuals** 56.1 If "as built" Drawings and/or operating and maintenance manuals are required, the Contractor shall supply them by the dates **stated in the SCC**.
- 56.2 If the Contractor does not supply the Drawings and/or manuals by the dates **stated in the SCC** pursuant to GCC Sub-Clause 55.1, or they do not receive the Project Manager's approval, the Project Manager shall withhold the amount **stated in the SCC** from payments due to the Contractor.
- 57. Termination** 57.1 The Employer or the Contractor may terminate the Contract if the other party causes a fundamental breach of the Contract.
- 57.2 Fundamental breaches of Contract shall include, but shall not be limited to, the following:
- (a) the Contractor stops work for 30 days when no stoppage of work is shown on the current Program and the stoppage has not been authorized by the Project Manager;

- (b) the Project Manager instructs the Contractor to delay the progress of the Works, and the instruction is not withdrawn within 30 days;
- (c) the Employer or the Contractor is made bankrupt or goes into liquidation other than for a reconstruction or amalgamation;
- (d) a payment certified by the Project Manager is not paid by the Employer to the Contractor within 60 days of the date of the Project Manager's certificate;
- (e) the Project Manager gives Notice that failure to correct a particular Defect is a fundamental breach of Contract and the Contractor fails to correct it within a reasonable period of time determined by the Project Manager;
- (f) the Contractor does not maintain a Security, which is required;
- (g) the Contractor has delayed the completion of the Works by the number of days for which the maximum amount of liquidated damages can be paid, as **defined in the SCC**; or
- (h) if the Contractor, in the judgment of the Employer, has engaged in corrupt or fraudulent practices in competing for or in executing the Contract, pursuant to GCC Clause 57.1.

57.3 When either party to the Contract gives notice of a breach of Contract to the Project Manager for a cause other than those listed under GCC Sub-Clause 56.2 above, the Project Manager shall decide whether the breach is fundamental or not.

57.4 Notwithstanding the above, the Employer may terminate the Contract for convenience.

57.5 If the Contract is terminated, the Contractor shall stop work immediately, make the Site safe and secure, and leave the Site as soon as reasonably possible.

58. Fraud and Corruption

58.1 If the Employer determines that the Contractor has engaged in corrupt, fraudulent, collusive, coercive or obstructive practices, in competing for or in executing the Contract, then the Employer may, after giving 15 days' notice to the Contractor, terminate the Contractor's employment under the Contract and expel him from the Site, and the provisions of Clause 57 shall apply as if such expulsion had been made under Sub-Clause 57.5 [Termination by Employer].

58.2 Should any employee of the Contractor be determined to have engaged in corrupt, fraudulent, collusive, coercive, or obstructive practice during the execution of the Works, then that employee shall be removed in accordance with Clause 9.

58.3 For the purposes of this Sub-Clause:

- (i) “corrupt practice” is the offering, giving, receiving or soliciting, directly or indirectly, of anything of value to influence improperly the actions of another party;
- (ii) “fraudulent practice” is any act or omission, including a misrepresentation, that knowingly or recklessly misleads, or attempts to mislead, a party to obtain a financial or other benefit or to avoid an obligation;
- (iii) “collusive practice” is an arrangement between two or more parties designed to achieve an improper purpose, including to influence improperly the actions of another party;
- (iv) “coercive practice” is impairing or harming, or threatening to impair or harm, directly or indirectly, any party or the property of the party to influence improperly the actions of a party;
- (v) “obstructive practice” is
 - (a) deliberately destroying, falsifying, altering or concealing of evidence material to the investigation or making false statements to investigators in order to materially impede an investigation into allegations of a corrupt, fraudulent, coercive or collusive practice; and/or threatening, harassing or intimidating any party to prevent it from disclosing its knowledge of matters relevant to the investigation or from pursuing the investigation; or
 - (b) acts intended to materially impede the exercise of an inspection and audit rights provided for under Sub-Clause 22.2.

59. Payment upon Termination

59.1 If the Contract is terminated because of a fundamental breach of Contract by the Contractor, the Project Manager shall issue a certificate for the value of the work done and Materials ordered less advance payments received up to the date of the issue of the certificate and less the percentage to apply to the value of the work not completed, as **indicated in the SCC**. Additional Liquidated Damages shall not apply. If the total amount due to the Employer exceeds any payment due to the Contractor, the difference shall be a debt payable to the Employer.

59.2 If the Contract is terminated for the Employer’s convenience or because of a fundamental breach of Contract by the Employer, the Project Manager shall issue a certificate for the value of the work done, Materials ordered, the reasonable cost of removal of Equipment, repatriation of the Contractor’s personnel employed solely on the Works, and the Contractor’s costs of protecting and securing the Works, and less advance payments received up to the date of the certificate.

60. Property

60.1 All Materials on the Site, Plant, Equipment, Temporary Works, and Works shall be deemed to be the property of the Employer if the Contract is terminated because of the Contractor's default.

61. Release from Performance

61.1 If the Contract is frustrated by the outbreak of war or by any other event entirely outside the control of either the Employer or the Contractor, the Project Manager shall certify that the Contract has been frustrated. The Contractor shall make the Site safe and stop work as quickly as possible after receiving this certificate and shall be paid for all work carried out before receiving it and for any work carried out afterwards to which a commitment was made.

Section VI. Special Conditions of Contract

These clauses should be read in conjunction with the General Conditions of Contract

A. General	
SCC 1.1 (r)	The Employer is: Environmental Investment Fund of Namibia
SCC 1.1 (v)	The Intended Completion Date for the whole of the Works shall be 3 months after the contract signing date
SCC 1.1 (y)	The Project Manager is: <i>DUNAMIS Consulting Engineers & Project Managers</i> <i>PO Box 3757,</i> <i>Windhoek,</i> <i>Namibia</i>
SCC 1.1 (dd)	“The Start Date shall be: Not more than 14 calendar days after site handover
SCC 1.1 (hh)	The Works consist of: Construction of Water Treatment Pump House and Civil works.
SCC 2.2	Sectional Completions are: <i>Not Applicable</i>
SCC 2.3(i)	The following documents also form part of the Contract: <i>1) Notification of award</i> <i>2) The bid</i> <i>3) The Conditions of Contract</i> <i>4) The Bills of Quantities</i> <i>5) Project Specifications</i> <i>6) Any addendum</i>
SCC 5.1	The Project manager may delegate any of his duties and responsibilities.
SCC 6.1	Delivery address for notices is: Employer: Head of Procurement, Environmental Investment Fund of Namibia PO Box 28157

	<p>Auas Valley Namibia</p> <p>Contractor:</p>
SCC 8.1	Schedule of other contractors: <i>Not Applicable</i>
SCC 13.1	Except for the cover mentioned in (d)(i) hereunder, the other insurance covers shall be in the joint names of the Contractor and the Employer and the minimum insurance amounts shall be: <i>Not applicable</i>
SCC 20.1	The Site Possession Date(s) shall be: At Kavango West region on date to be confirmed
SCC 23.1 & SCC 23.2	Appointing Authority for the Adjudicator: <i>No Adjudicator shall be appointed under this Contract.</i>
SCC 24.	<p>In case a dispute of any kind arises between the Employer and the Contractor in connection with, or arising out of, the contract or the execution of works or after completion of works and whether before or after repudiation or other termination of Contract, including any dispute as to any opinion, instruction, determination, certificate or valuation of the Employer’s Representative, the matter in dispute shall, in the first place, be referred in writing to the employer’s representative, with a copy to the other party.</p> <p>The Employer and the Contractor shall make every effort to resolve the dispute amicably by direct informal negotiation. If, after thirty (30) days, the parties have failed to resolve their dispute or difference by such mutual consultation, then either the Public Entity or the Contractor may give notice to the other party of its intention to refer the matter to the competent courts of Namibia</p>
SCC 24.3	Hourly rate and types of reimbursable expenses to be paid to the Adjudicator: Not applicable.
SCC 24.4	<p><i>For large contracts with domestic contractor or for contract with foreign contractor:</i></p> <p>Not Applicable</p>
B. Time Control	
SCC 25.1	The Contractor shall submit for approval a Program for the Works within 7 days from the date of the Notification of award.

SCC 25.3	The period between Program updates is 7 days. The amount to be withheld for late submission of an updated Program is <i>N\$1000.00</i>
C. Quality Control	
SCC 33.1	The Defects Liability Period is: <i>180</i> days.
SCC 39.7	Interim Payment for Plant and Material on site “ is ” applicable.
D. Cost Control	
SCC 41.1 (l)	<i>Namibia Meteorological Services to define adverse weather conditions</i>
SCC 43.1	The currency of the Employer’s country is: Namibian Dollars
SCC 44.1	Notwithstanding allowance in GCC44.1. Price adjustments to be in accordance with the relevant indices of road maintenance works
SCC 45.1	The proportion of payments retained is: <i>Not Applicable</i>
SCC 46.1	The liquidated damages for the whole of the Works are: applicable to contractors for non-completion of Government Projects (Directive No. MWT 01/2015-2016): Penalty calculations per calendar day to be determined at contract signing, being calculated on the <u>Tendered Amount</u> <u>A) PENALTY CALCULATIONS PER CALENDAR DAY</u> <u>Contract value under N\$ 20 million</u> <i>Penalties calculation is fixed at N\$ 1000.00 per calendar day</i>
SCC 47.1	The Bonus for the whole of the Works is: <i>Not Applicable</i>
SCC 48.1	The Advance Payments shall be: <i>Applicable</i>
SCC 49.1	The Performance Security amount is: <i>Not Applicable</i>
E. Finishing the Contract	
SCC 55.1	<i>The Contractor shall supply the Project Manager with a detailed account of the total amount that the Contractor considers payable under the Contract before the end of the Defects Liability Period. The Project Manager shall issue a Defects Liability Certificate and certify any final payment that is due to the Contractor within 60 days of receiving the Contractor’s account if it is correct and complete. If it is not, the Project Manager shall issue within 60 days a schedule that states the scope of the corrections or additions that are necessary. If the Final Account is still unsatisfactory after it has been</i>

	<i>resubmitted, the Project Manager shall decide on the remedial action.</i>
SCC 56.1	Operating and maintenance manuals should be supplied to the employer by the contractor no later than: Should be handed to the beneficiaries at Practical completion.
SCC 56.2	The amount to be withheld for failing to produce “as built” drawings and/or operating and maintenance manuals by the date required in GCC 55.1 will be <i>not applicable</i>
SCC 57.2 (g)	The maximum number of days is: <i>90 days</i>
SCC 59.1	The percentage to apply to the value of the work not completed, representing the Employer’s additional cost for completing the Works, is <i>0%</i>

Part 3: Contract Forms

Section VII. Contract Forms

Table of Forms

Typical Notification of Award	33
Typical Letter of Acceptance	34
Typical Contract Agreement	35
Performance Security (Bank Guarantee)	37
Appendix to Bid.....	38

Typical Notification of Award

[on letter head of the Employer]

..... *[date]*

To: *[name and address of the Contractor]*

Subject: *[Notification of Award Contract No]*

This is to notify you that your Bid dated *[insert date]* for execution of the
.*[insert name of the contract and identification number, as given in the Appendix to Bid]* .
. for the Accepted Contract Amount of. *[insert amount in numbers
and words in Namibian Dollars]*, as corrected and modified in accordance with the
Instructions to Bidders is hereby accepted by *(insert name of Public Entity)*.

You are requested to furnish the Performance Security within 21 days in accordance
with the General Conditions of Contract, using for that purpose of the Performance
Security Form included in Section VIII (Contract Forms) of the Bidding Document.

Authorized Signature:

Name and Title of Signatory:

Name of Public Entity:

Attachment: Contract Agreement

*[This form is simply a guide and may be amended as far as possible to suit
requirements of the public entity]*

Typical Letter of Acceptance

[on letterhead paper of the Employer]

..... *[date]*

To: *[name and address of the Contractor]*

Subject: *[Notification of Award Contract No.]*

This is to notify you that your Bid dated *[insert date]* for execution of the
.*[insert name of the contract and identification number, as given in the Appendix to Bid]* .
. for the Accepted Contract Amount of the equivalent of *[insert amount in numbers and words and name of currency]*, as corrected and modified in accordance with the Instructions to Bidders is hereby accepted by *(insert name of Public Body)*.

You are requested to furnish the Performance Security within 21 days in accordance with the General Conditions of Contract, using for that purpose of the Performance Security Form included in Section VI (Contract Forms) of the Bidding Document.

Authorized Signature:

Name and Title of Signatory:

Name of Public Body:

Attachment: Contract Agreement

Typical Contract Agreement

THIS AGREEMENT made on the, between Environmental Investment Fund of Namibia. (hereinafter “the Employer”), of the one part, and (hereinafter “the Contractor”), of the other part:

WHEREAS the Employer desires that the Works known as Water Treatment Project to improve local communities’ livelihoods in Namibia should be executed by the Contractor, and has accepted a Bid by the Contractor for the execution and completion of these Works and the remedying of any defects therein,

The Employer and the Contractor agree as follows:

1. In this Agreement words and expressions shall have the same meanings as are respectively assigned to them in the Contract documents referred to.
2. The following documents shall be deemed to form and be read and construed as part of this Agreement. This Agreement shall prevail over all other Contract documents.
 - (a) the Notification of award (Letter of Acceptance)
 - (b) Bid Submission Form
 - (c) the Bid
 - (d) the Addenda Nos
 - (e) Bidding data Sheets
 - (f) Appendix to Tender
 - (g) the Conditions of Contract;
 - (h) the Specification
 - (i) the Drawings; and
 - (j) the completed Schedules,
3. In consideration of the payments to be made by the Employer to the Contractor as indicated in this Agreement, the Contractor hereby covenants with the Employer to execute the Works and to remedy defects therein in conformity in all respects with the provisions of the Contract.
4. The Employer hereby covenants to pay the Contractor in consideration of the execution and completion of the Works and the remedying of defects therein, the Contract Price or such other sum as may become payable under the provisions of the Contract at the times and in the manner prescribed by the Contract.

5. IN WITNESS whereof the parties hereto have caused this Agreement to be executed in accordance with the laws of Namibia on the day, month and year indicated above.

Signed by:	Name:..... Signature:.....	Signed by:	Name:..... Signature:.....
for and on behalf of the Employer		for and on behalf the Contractor	
Name:..... Date:.....		Name:..... Date:.....	
in the presence of: (Witness)	Name:..... Signature:.....	in the presence of: (Witness)	Name:..... Signature.....
Address..... Date.....		Address..... Date.....	

Performance Security (Bank Guarantee)

[The bank, as requested by the successful Bidder, shall fill in this form in accordance with the instructions indicated]

Date: *[insert date (as day, month, and year) of Bid Submission]*

Procurement Reference No. and title: *[insert no. and title of bidding process]*

Bank’s Branch or Office: *[insert complete name of Guarantor]*

Beneficiary: *[insert complete name of Purchaser]*

PERFORMANCE GUARANTEE No.: *[insert Performance Guarantee number]*

We have been informed that *[insert complete name of Supplier]* (hereinafter called "the Supplier") has entered into Contract No. *[insert number]* dated *[insert day and month]*, *[insert year]* with you, for the supply of *[description of goods and related services]* (hereinafter called "the Contract").

Furthermore, we understand that, according to the conditions of the Contract, a Performance Guarantee is required.

At the request of the Supplier, we hereby irrevocably undertake to pay you any sum(s) not exceeding *[insert amount(s)³ in figures and words]* upon receipt by us of your first demand in writing declaring the Supplier to be in default under the Contract, without cavil or argument, or your needing to prove or to show grounds or reasons for your demand or the sum specified therein.

This Guarantee shall expire no later than the *[insert number]* day of *[insert month]* *[insert year]*,⁴ and any demand for payment under it must be received by us at this office on or before that date.

.....**Bank’s seal and authorized signature(s)**
.....

³ The Bank shall insert the amount(s) specified in the SCC and denominated, as specified in the SCC, in the currency of the Contract.

⁴ Dates established in accordance with Clause 18.4 of the General Conditions of Contract (“GCC”), taking into account any warranty obligations of the Supplier under Clause 16.2 of the GCC intended to be secured by a partial Performance Guarantee. The Purchaser should note that in the event of an extension of the time to perform the Contract, the Purchaser would need to request an extension of this Guarantee from the Bank. Such request must be in writing and must be made prior to the expiration date established in the Guarantee. In preparing this Guarantee, the Purchaser might consider adding the following text to the Form, at the end of the penultimate paragraph: “We agree to a one-time extension of this Guarantee for a period not to exceed [six months] [one year], in response to the Purchaser’s written request for such extension, such request to be presented to us before the expiry of the Guarantee.”

Appendix to Bid

*[Note: with the exception of the items for which the Employer's requirements have been inserted, the following information, indicated by an *, must be completed before the Bid is submitted]*

Item	Sub-Clause	Data
Validity period of Bid	ITB 3	60 days from closing date
Employer's name and address	SCC6.1	The Accounting Officer of Environmental Investment Fund and acting on behalf of the said Environmental Investment Fund
Contractor's name and address*	SCC6.1	*
Time for Completion of the Works	ITB 6.3(b)	__90 days / 3 months
Governing Law		Republic of Namibia
Language for communications	GCC3	English
Time for access to the Site	SCC20.1	N/A
Amount of Performance Security	ITB40.1 / SCC49.1	10% of Accepted Contract Amount
Normal working hours	GCC52	as per Labour Act 11 of 2007

INITIALS OF SIGNATORY OF BIDDER _____

Extension of Time: maximum cost			N/A
Late completion		SCC46.1	N\$ 1000 per calendar day
Maximum amount of delay damages		SCC46.1	N\$ 30,000.00
Adjustments for Changes in cost		GCC36/GCC42/GCC44.1/ SCC44.1	For payments each Month in Namibian Dollar
Coefficient; Scope of index	Country of origin; Currency of index	Source of index; Title / definition	Value on stated date(s)* Value Date
a = 0.55 CPI	Namibia	Central Bureau of Statistics	
b = 0.35 Wages	Namibia	Government Gazette	
c = 0.1 Fuel	Namibia	Kavango West Diesel Pumps	

*These values and dates confirm the definition of each index, but do not define Base Date indices

Total advance payment	SCC48.1	N/A
Interim payment instalments	GCC39	28 days after delivery of each statement
Currencies and proportions	GCC43.1	Namibian Dollars

Minimum amount of Interim Payment Certificates		N\$ 50 000.00
---	--	---------------

INITIALS OF SIGNATORY OF BIDDER _____

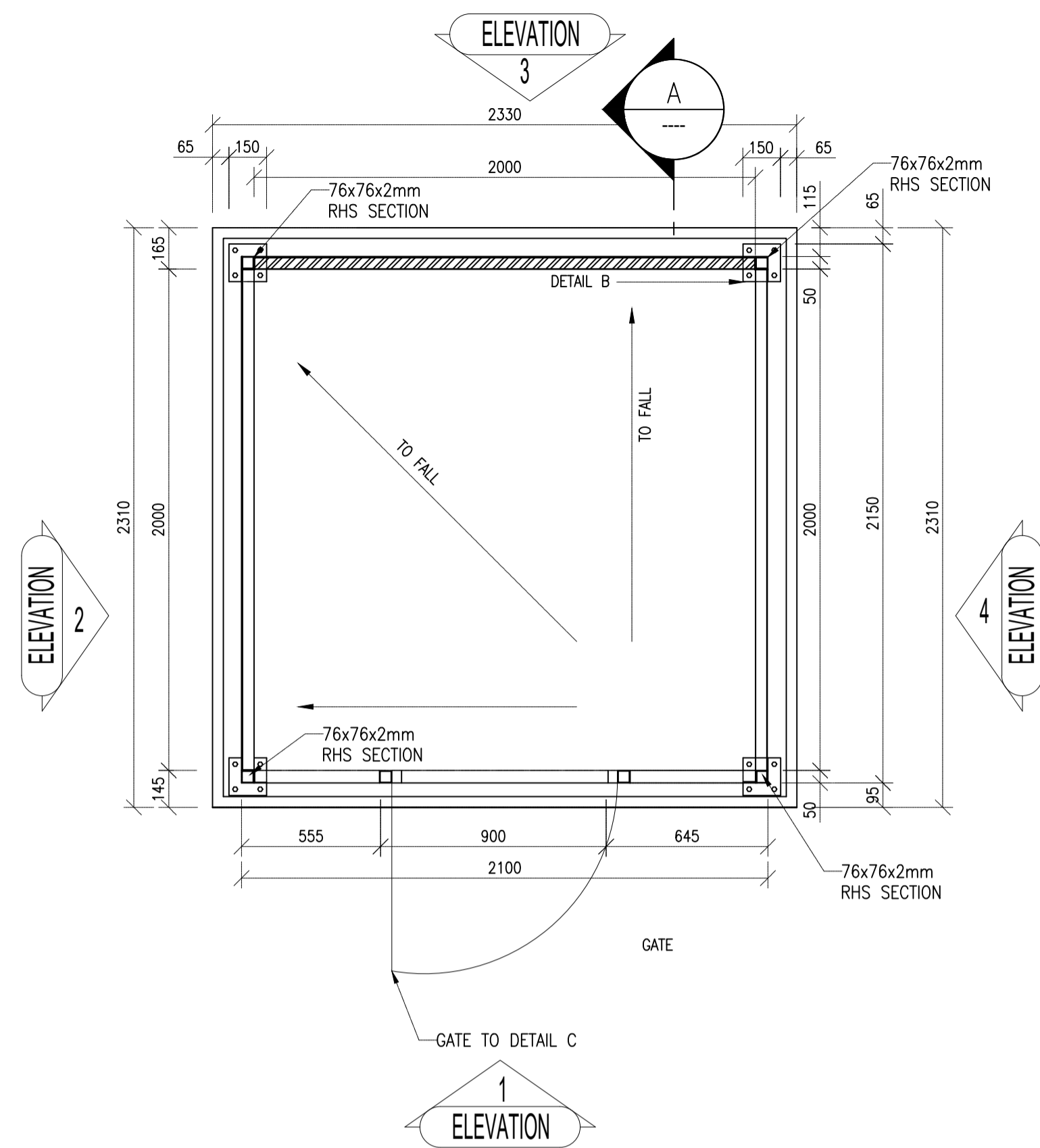

LAYOUT PLAN OF REVERSE OSMOSIS UNIT PLINTH
SCALE 1:50

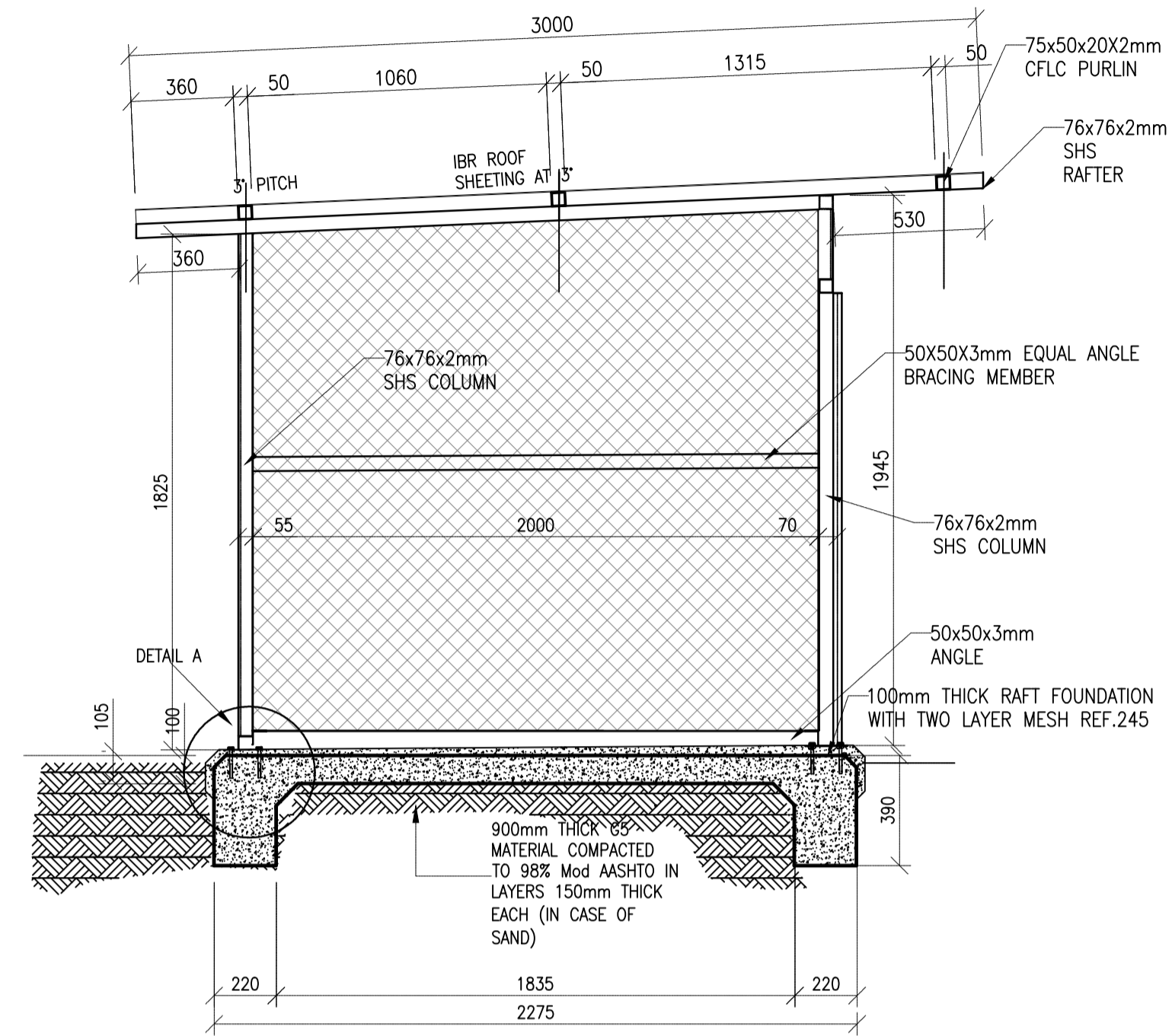

SECTION A
SCALE 1:50

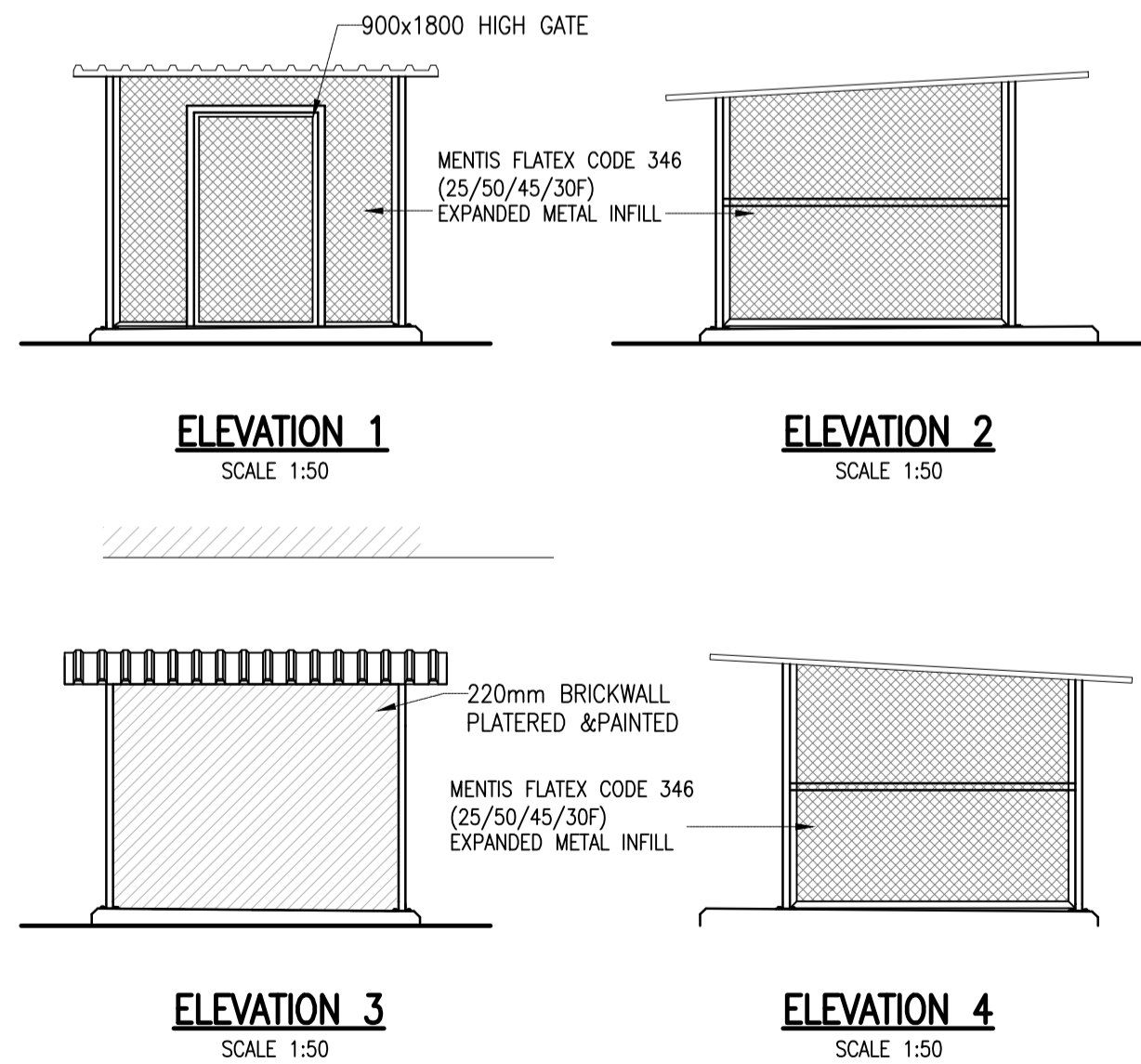

ELEVATION 1
SCALE 1:50

ELEVATION 2
SCALE 1:50

ELEVATION 3
SCALE 1:50

ELEVATION 4
SCALE 1:50

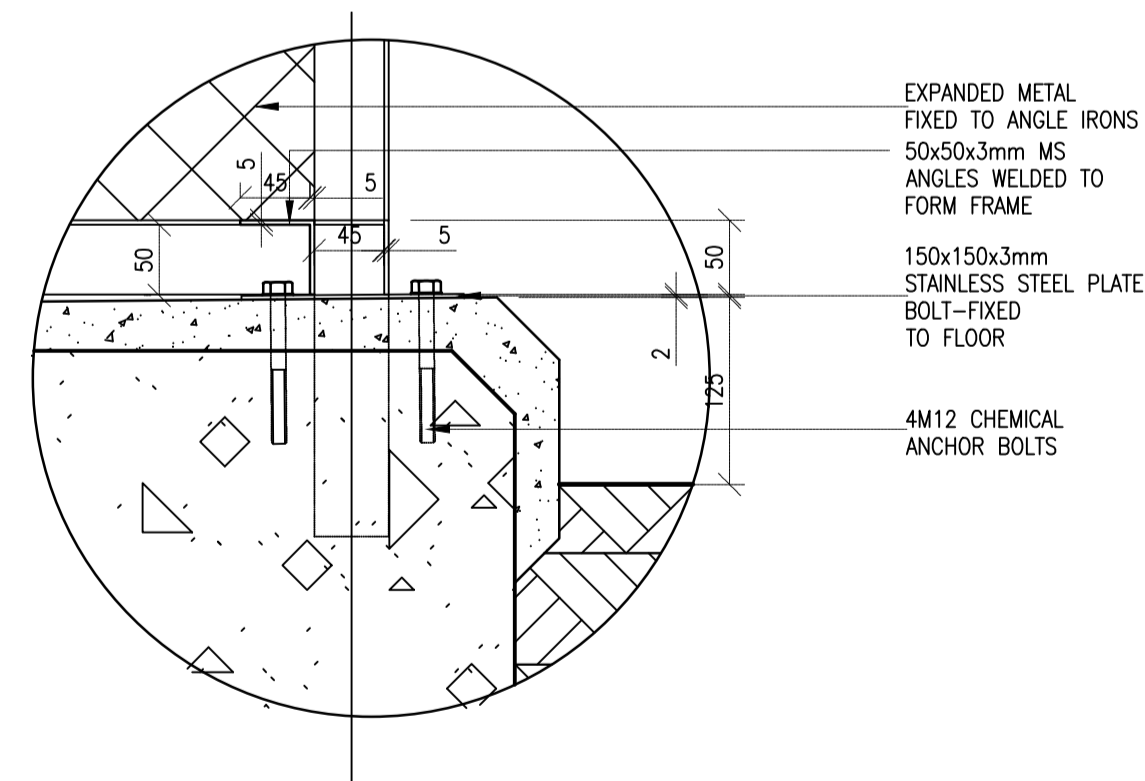

DETAIL A: SECTION OF FIXING PLATE
SCALE 1:5

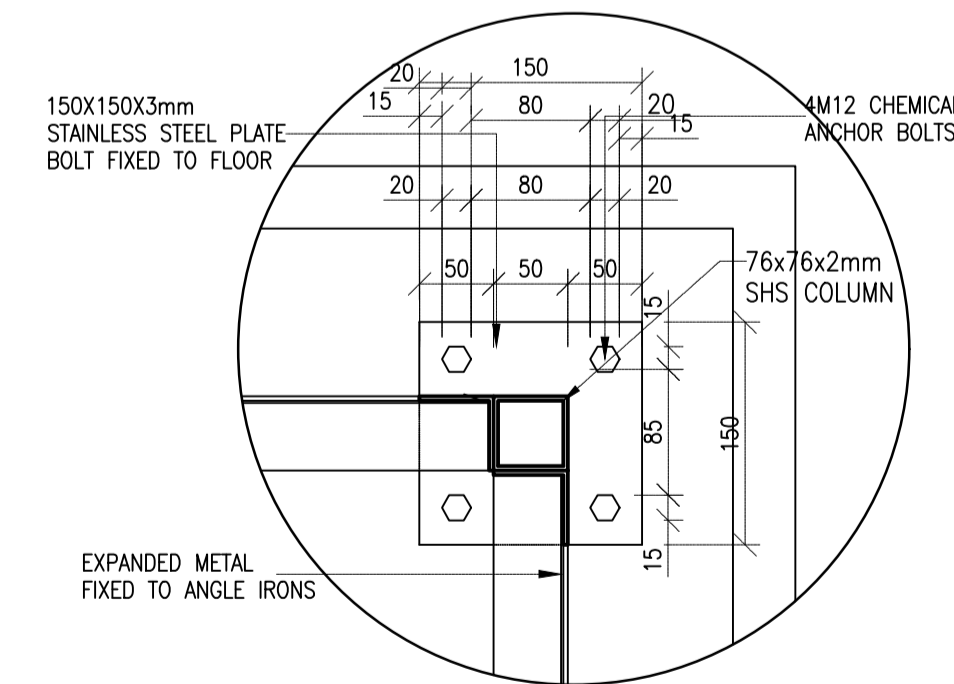

DETAIL B: SECTION OF FIXING PLATE
SCALE 1:5

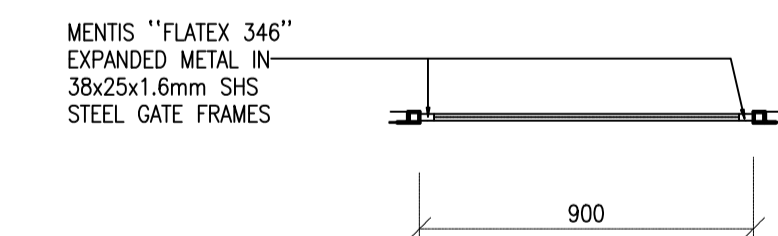

DETAIL C: PLAN OF GATE
SCALE 1:20

CLIENT
ENVIRONMENTAL INVESTMENT FUND
8933 HEINITZBURG HEIGHTS
c/o HEINITZBURG & DR. THEO-BEN GURRAB
STREETS,
KLEIN WINDHOEK
WINDHOEK, NAMIBIA
TEL:+264 (61) 431 7700
FAX:+264 (61) 240 339



PROJECT
REVERSE OSMOSIS WATER TREATMENT PLANT

CONSULTANTS
CIVIL ENGINEER:
DUNAMIS CONSULTING ENGINEERS
PO BOX 3757
WINDHOEK
TEL:+264 (61) 236 911
FAX:+264 (61) 256 777



GENERAL NOTES:
1) COPYRIGHT IS RESERVED ON ALL DRAWING AND DESIGNS.
2) NO PART OF THIS DRAWING MAY BE SCALED.
3) ALL DIMENSION AND LEVEL GIVEN MUST BE CHECKED BEFORE COMMENCING ANY WORK. ANY DISCREPANCIES MUST BE REPORT TO THE ENGINEER WITHOUT DELAY.
4) USE COORDINATE SYSTEM L₀ 23/19.

DESIGNED	I.N	MUNICIPAL APPROVAL	DATE
DRAWN	I.N	CLIENT'S APPROVAL	DATE
CHECKED	S.K		
SCALE	AS SHOWN		
COMPUTER PRINT	19001-CST-01		
DATE	2018.10.30		

DRAWING TITLE
RO HOUSING UNIT LAYOUT AND DETAILS - TYPE 2

DRAWING NUMBER	REVISION	DEPARTMENT
19001-CST-02	0	CIVIL